

**SUBARU**

# FRONT UNDER SPOILER

**INSTALLATION INSTRUCTIONS**

**GENUINE PART No : E2410FJ200## (WHERE ## IS THE COLOR CODE)**  
**APPLICABLE : IMPREZA (2015 MY~ )**

Please read Instructions before Installation.

## **! NOTES**

- Do not wash the vehicle for 24 hours following installation of this product.
- If this product requires cleaning after installation, wipe with a soft cloth or sponge with mild soap and wipe thoroughly with a dry cloth.
- Do not use gasoline, thinner, acid, alkaline or other solvent based products.
- The recommended adhesive surface temperature range is 77-104° F (25-40°C).
- If the surface temperature is below 59° F (15°C), heat the bonding tape and bumper surface to a temperature of 77-104° F (25-40°C).

## **COMPLETION IMAGE**

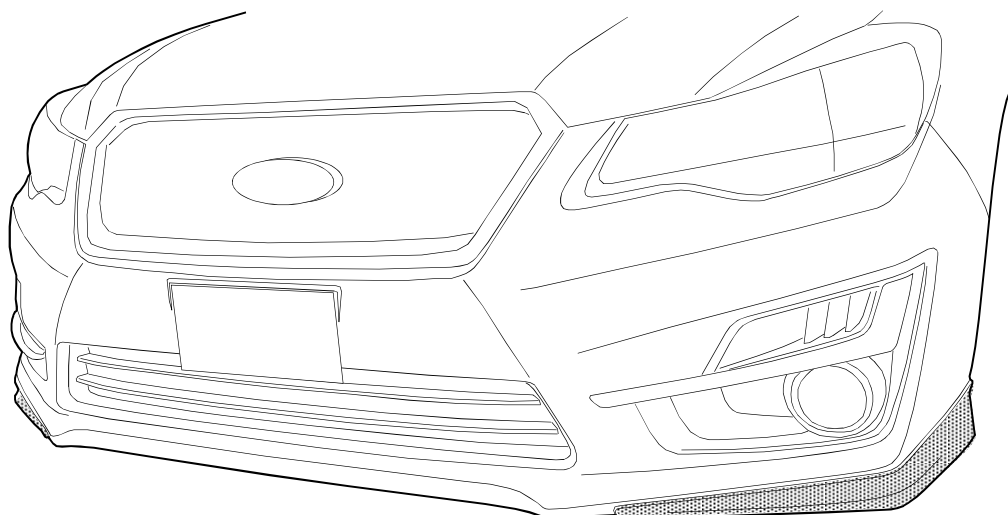

## COMPONENT PARTS

• Please check that all parts are present before starting installation.

No.	PART NAME	QTY
①	FR BUMPER SKIRT LH	1
②	FR BUMPER SKIRT RH	1
③	SCREWS	4
④	J-CLIP	4
⑤	RIVETS	4
⑥	TEMPLATE PAPERS (LH)	1

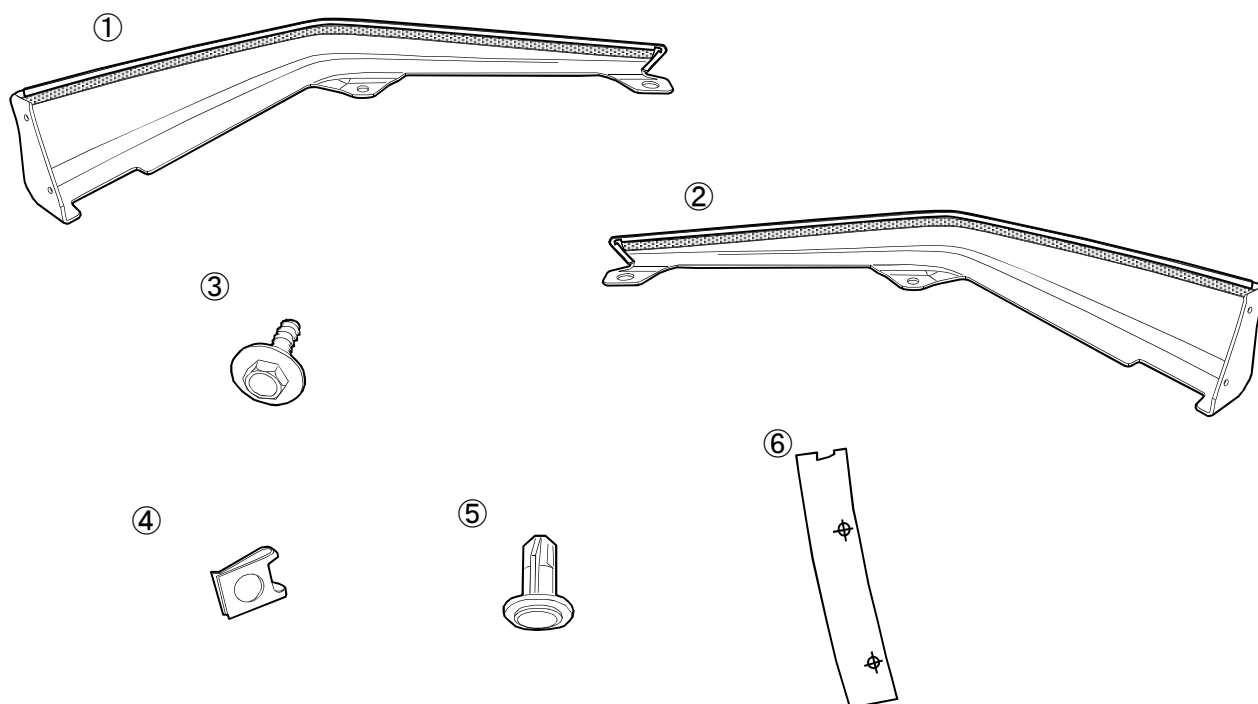

## TOOLS REQUIRED

• Neutral detergent (Alcohol) , Drill ( $\phi 3\text{mm}$  -  $\phi 6\text{mm}$ ) , Masking Tape  
Rag , Awl (Thumbtack) , Drive Ratchet & socket (8mm)

### NOTE :

• This instruction shows only LH side. Please repeat the steps on RH side.

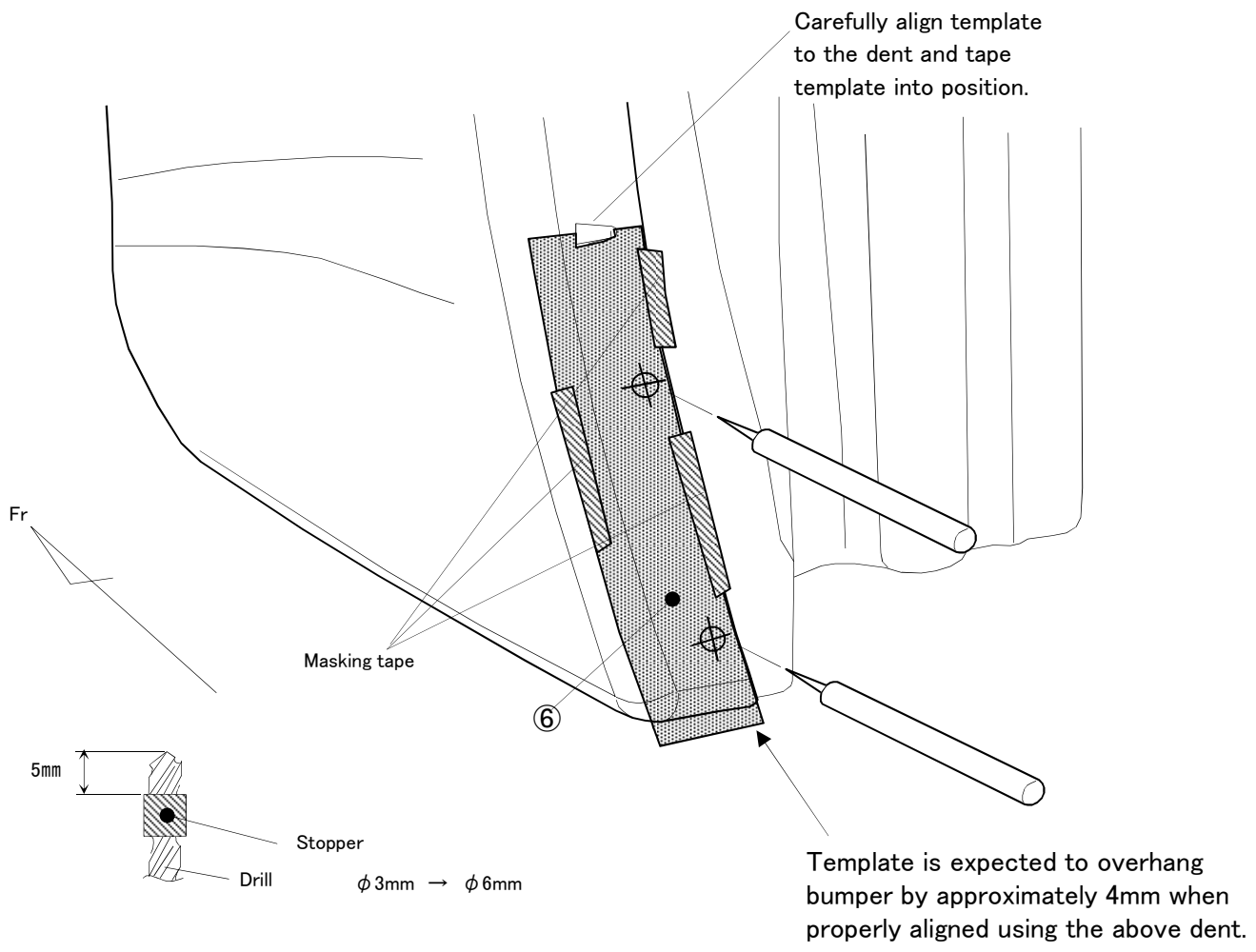

※Flip over template to use for installation on the right side.

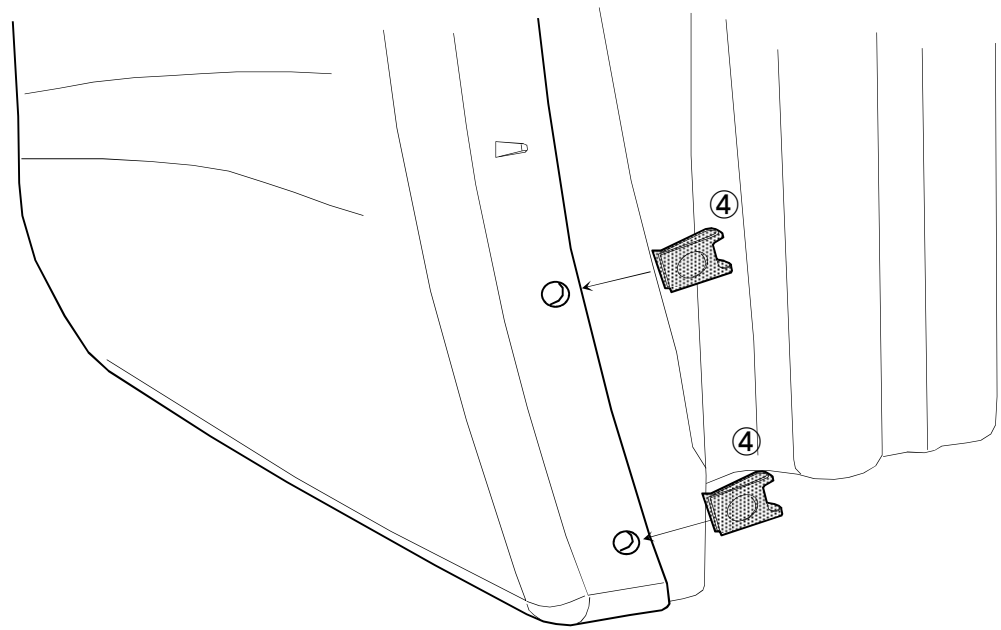

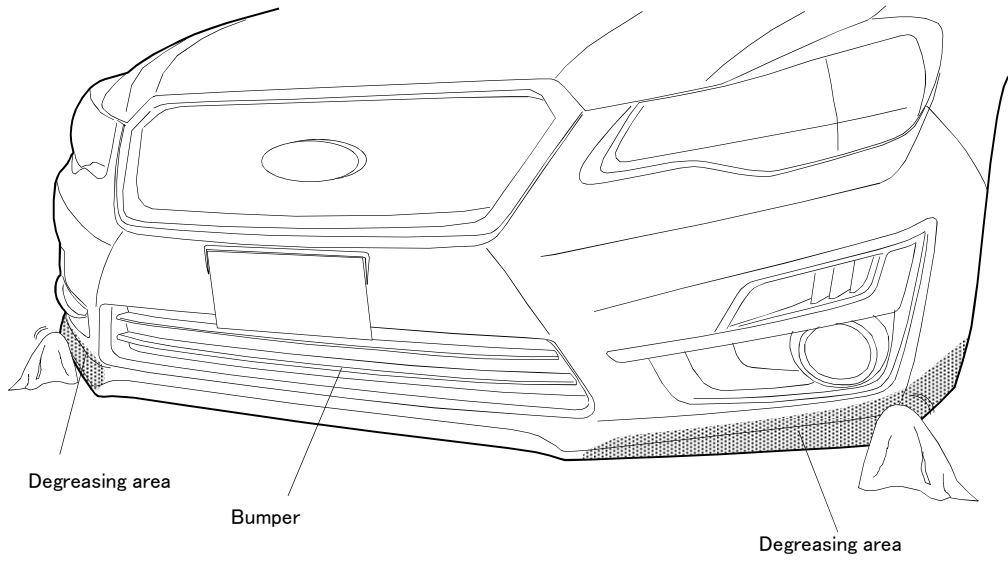

Remove this section of tape liner on each side completely.

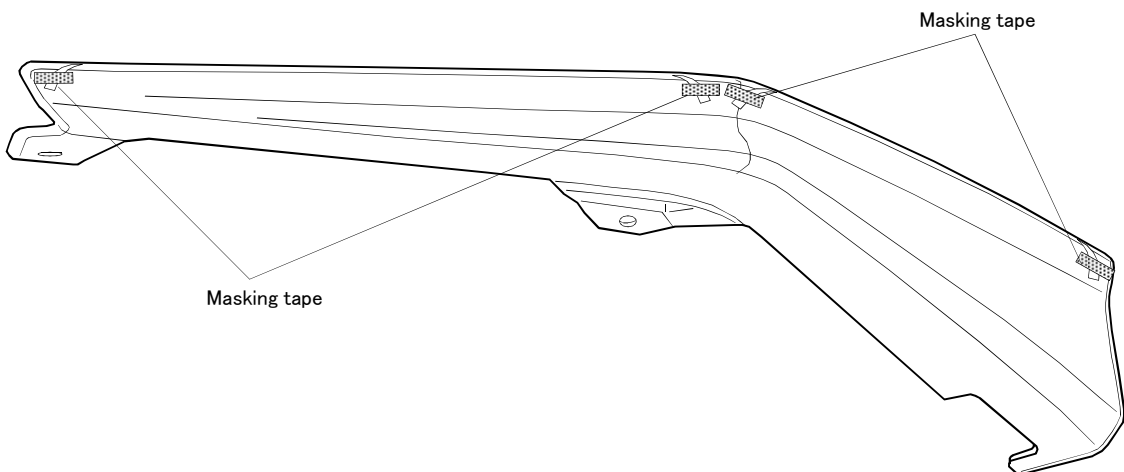
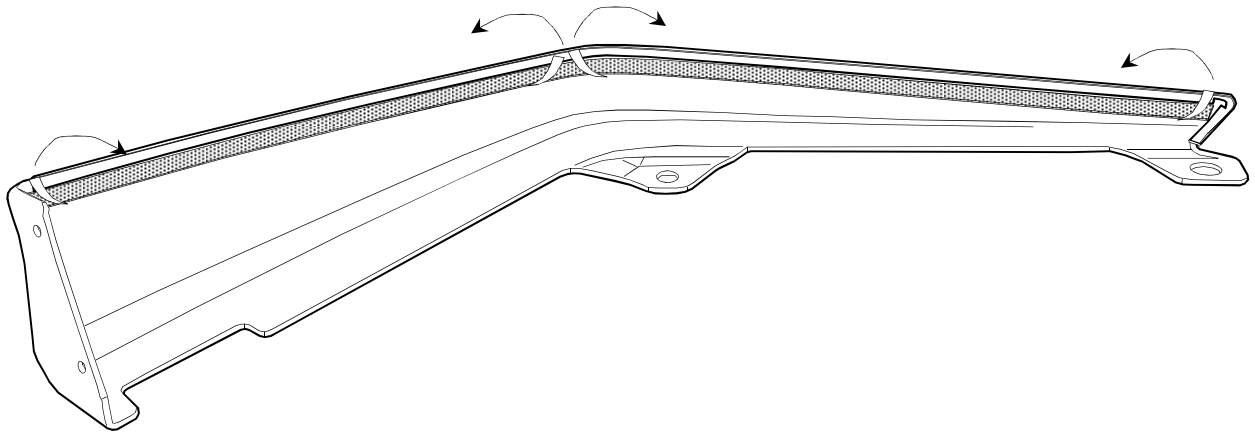

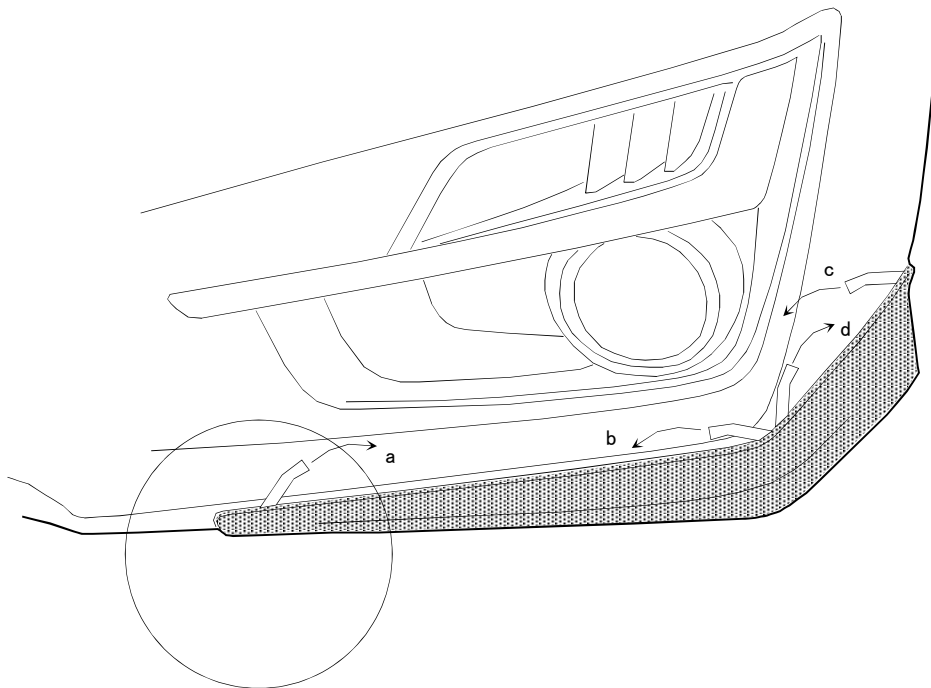
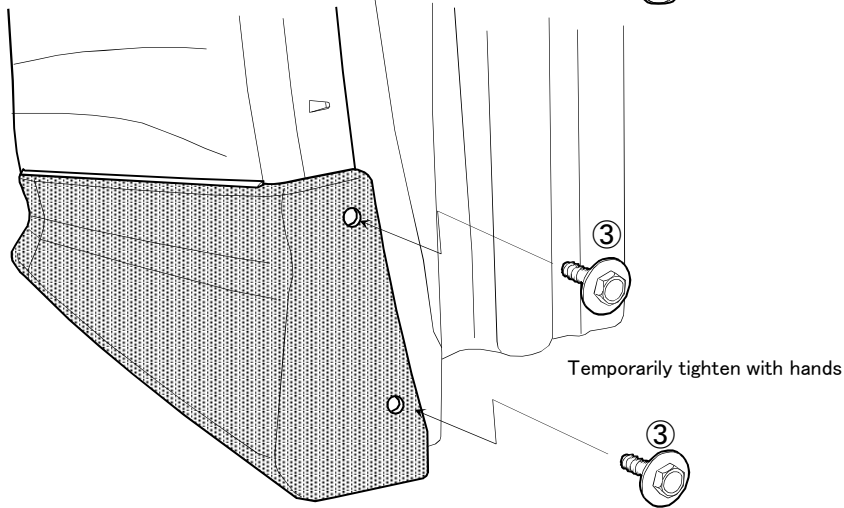
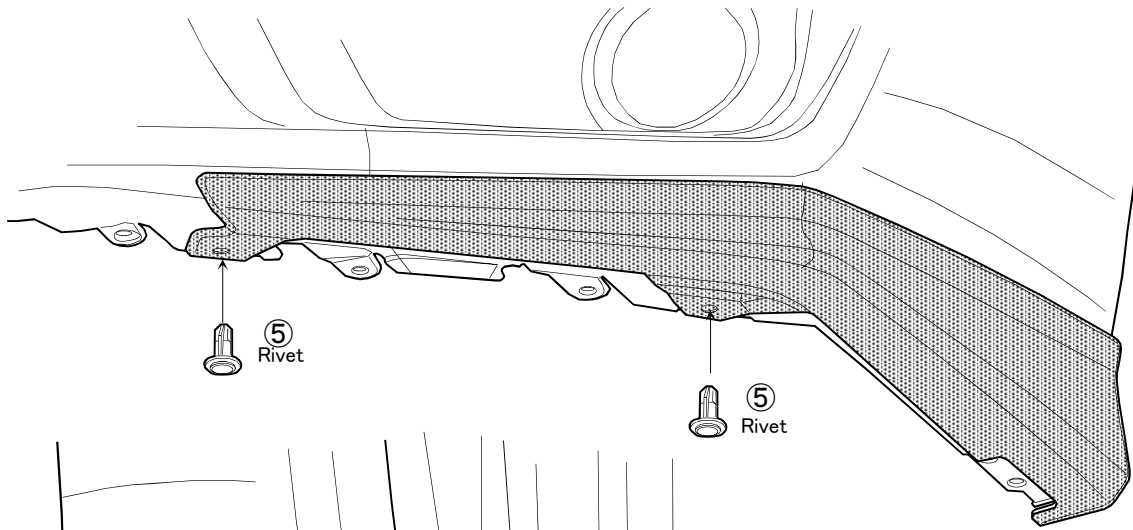

Removes tape liner in sequence from "a" to "d".

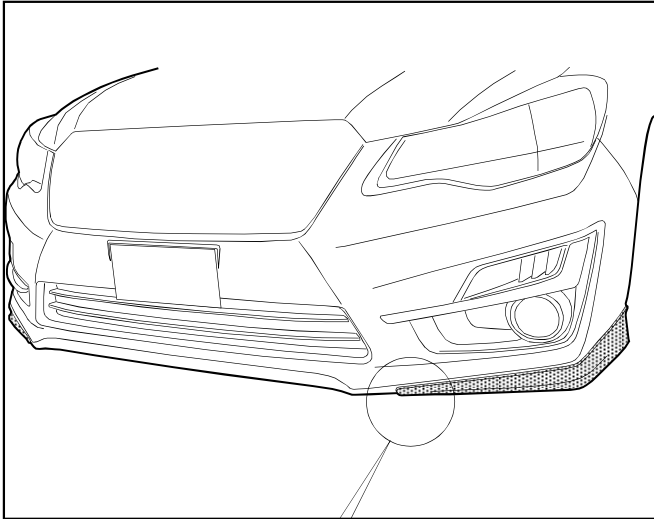

Once satisfied with placement, firmly press part onto bumper to ensure adhesion along entire vehicle surface. Continue to apply approximately 4.5kg (10lbs) of force along the taped area for a minimum of 10 seconds.

