



STI FT SPOILER

Installation Manual

Genuine part number : E2410SL000 STI FT SPOILER(Black)
E2410SL010 STI FT SPOILER(Cherry Red)
Applicable model : FORESTER(SL) TYPE A~

- This manual describes how to install and handle the STI FT SPOILER.
- Read this manual carefully before work and make sure to install it correctly.

Precautions

- Install the STI FT SPOILER by reading the Installation Manual carefully.
- Handle the STI FT SPOILER with care and do not let it fall.
- Do not install or use this product in any way other than described in this manual.
- We do not assume any responsibility for any trouble arising from failure to comply with the instructions in this manual.
- Double-sided tape is used to attach the STI FT SPOILER.
Attach it with care as once it is attached, it is extremely difficult to remove.

Installation Completion Illustration

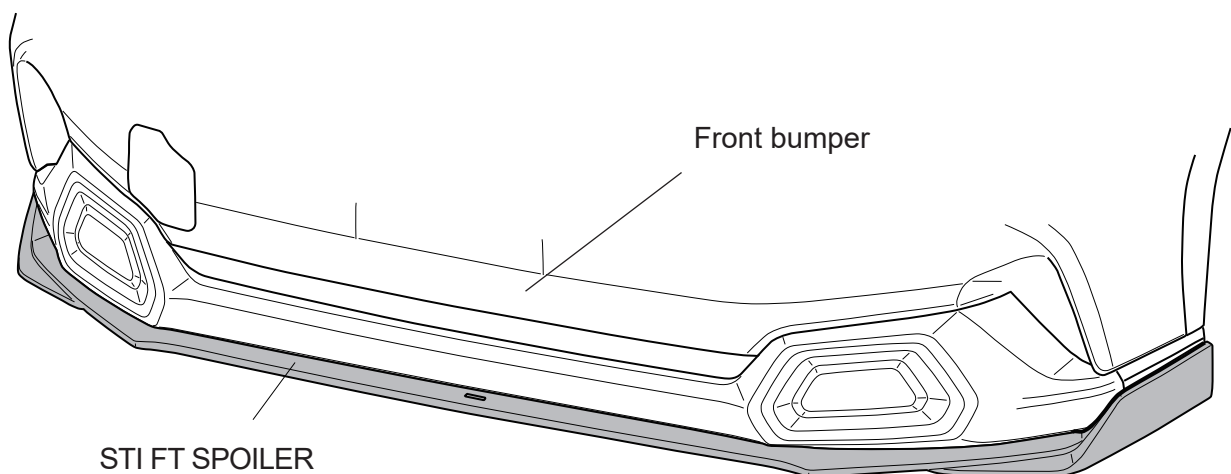

Components

- Make sure to check the components below before installation.

No.	Part Name	Qty
①	Front Spoiler	1
②	Clip	2
③	Washer	2
④	Wellnut	13
⑤	Bolt	13
⑥	J nut	2
⑦	Tapping screw	2
⑧	Pattern paper A to E 8 pieces set	1

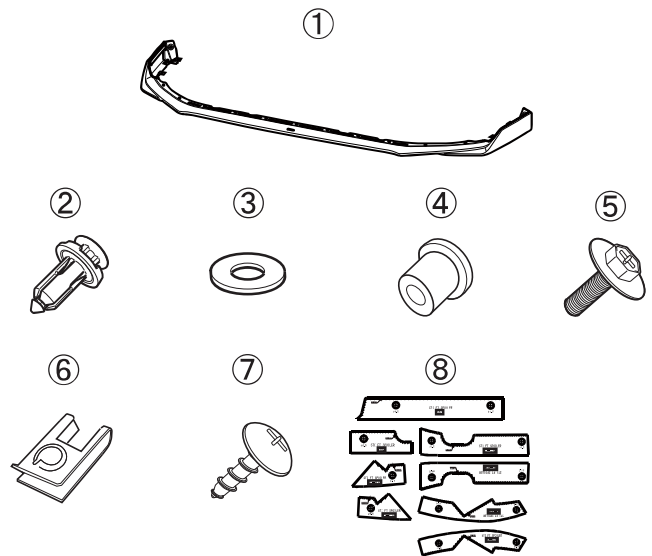

- E2410SL001 : Parts set ②×2 ③×2 ④×13 ⑤×13 ⑥×2 ⑦×2

Tools

- Degreasing agent (recommended nonane)
- Gloves
- Masking tape
- Clip remover
- Low head Phillips screwdriver
- Protective eyewear
- Needle
- Clean cloth
- Torque wrench
- Cloth adhesive tape
- Sandpaper
- Drill 3mm 6mm 9.5mm
- Phillips screwdriver

Before Work

- When installing this product, park the car on a level ground and apply the parking brake.
- When installing this product, be sure not to damage the car body.
- Before installing this product, wipe off any dirt or oil film from the Front bumper attachment surface with a soft waste cloth dampened in a neutral detergent. Then, let it dry completely before work.
- The adhesive strength is weakened significantly when the temperature is 15°C or low. In this case, use a dryer to warm the double-sided tape before attachment.
(Do not warm up excessively as doing so may result in deformation.)
- Be extremely careful not to let this product get wet by washing, etc. for 24 hours after attaching it.
Dosing so may cause the product to come off.
- To protect yourself from burns, make sure to stop the engine and let it cool completely before work
- When jacking up the vehicle, be sure to keep the ground level and a hard place where the jack does not bite, and be sure to support it with a rigid rack before carrying out the work.
- All pictures in this book are from the LH side. Do the same thing on the RH side.

Installation procedure

1. Drill holes in the Front Bumper

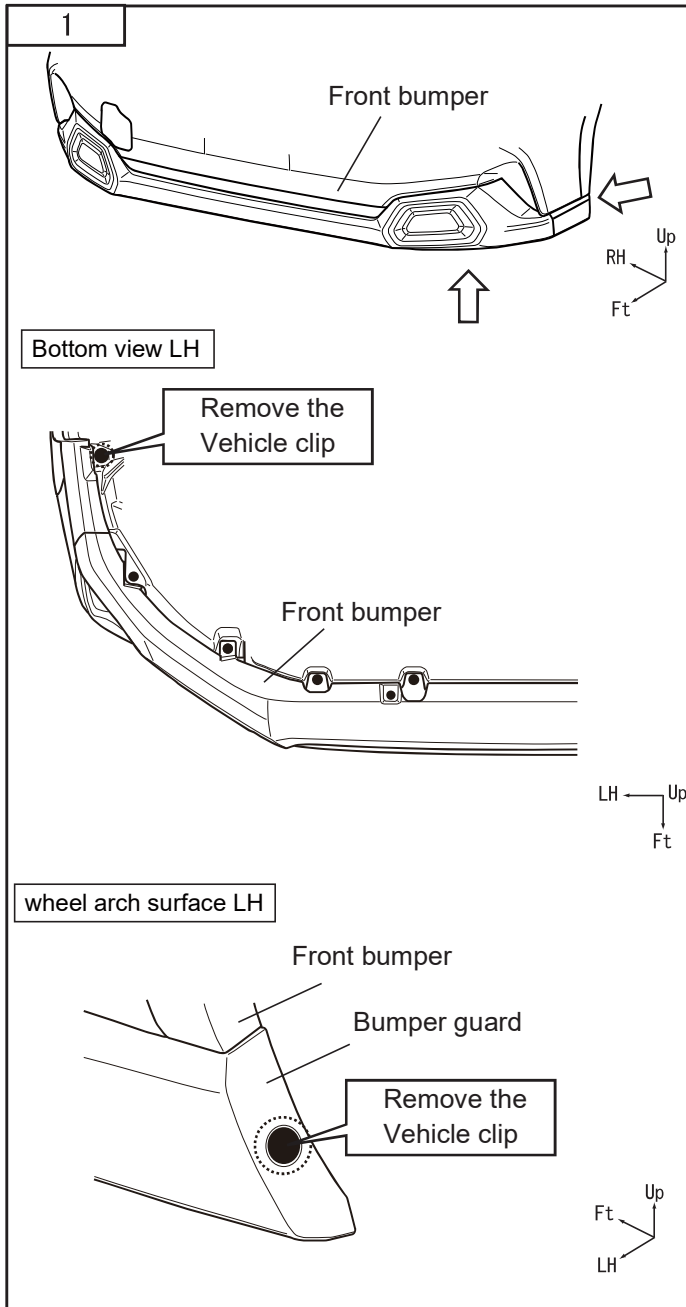

- (1) Remove the vehicle clip on the bottom of the Front bumper (1 places on one side) as shown in Fig 1.
(1 places each for LH and RH, 2 places in total)
- (2) Remove the vehicle clip that attaches the Bumper guard on the wheel arch side (1 places on one side) as shown in Fig 1.
(1 places each for LH and RH, 2 places in total)

CAUTION

- Do not reuse the removed vehicle clip.
- **Be sure to use the supplied clips.**

2

Bottom view

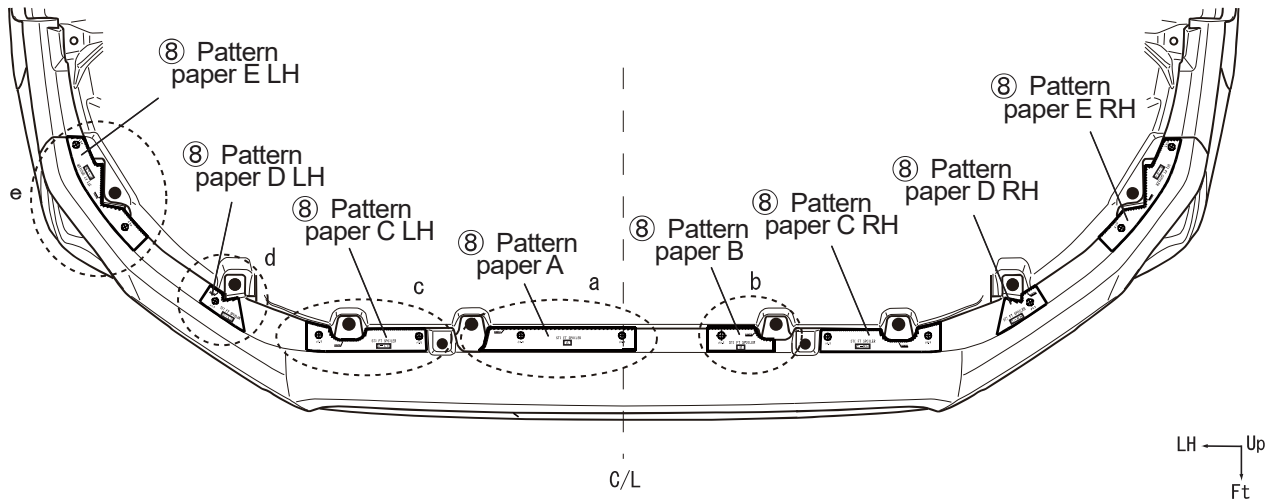

<Detail view a>

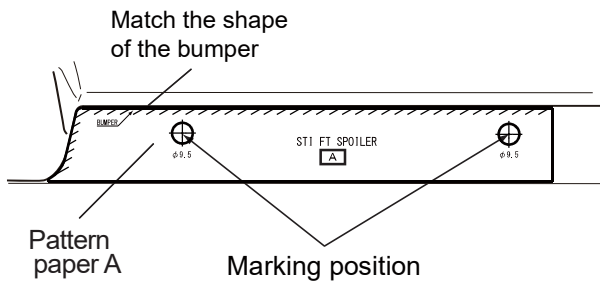

(3) As shown in Fig 2, ⑧ Pattern paper A to E on the bottom of the Front bumper, secure with masking tape, etc., and mark the center of the hole with a scriber, etc.

- ⑧ Pattern paper A 2 places
 - ⑧ Pattern paper B 1 place
 - ⑧ Pattern paper C LH,RH 2 places each
 - ⑧ Pattern paper D LH,RH 1 place each
 - ⑧ Pattern paper E LH,RH 2 places each
- 13 places each in total)

<Detail view c>

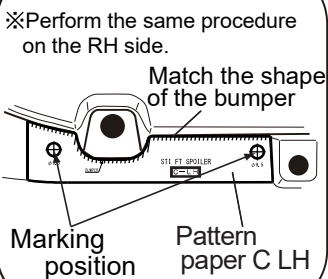

<Detail view b>

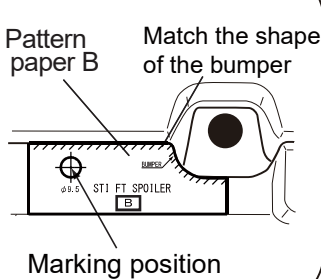

<Detail view e>

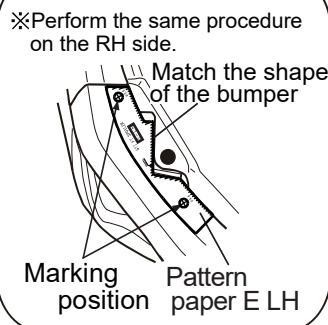

<Detail view d>

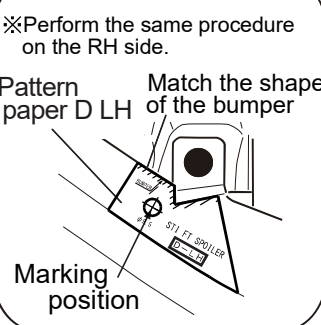

3

Bottom view LH

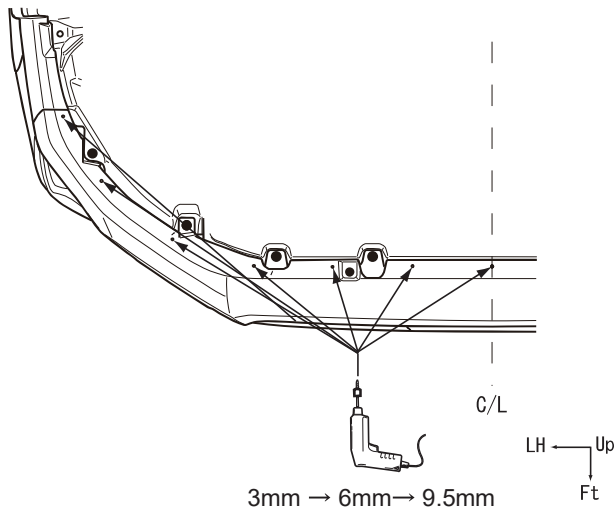

- (4) Remove ⑧ Pattern paper A to E and use a drill to drill holes in the center of the positions marked in (3).

Drill pilot holes in the order of 3mm, 6mm, and finally 9.5mm as shown in Fig 3.

- (1 place in the center
6 places each for LH and RH
13 places in total)

⚠ CAUTION

To prevent the drill from interfering with other parts when drilling, make a stopper with cloth adhesive tape, etc., at a point about 5 mm from the tip of the drill before working.

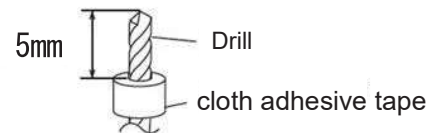

⚠ CAUTION

After drilling, remove the burrs around the hole.

2. Preparation for installation

4

Bottom view LH

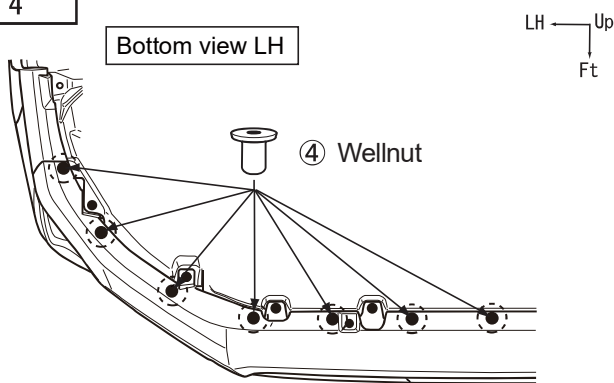

- (1) Insert the ④ Wellnut into the 9.5 mm hole.

- (1 place in the center
6 places each for LH and RH
13 places in total)

⚠ CAUTION

If it is difficult to insert the wellnut, do not twist it too much and insert it carefully.

5

wheel arch surface LH

Bumper guard

⑥ J nut

Up LH
Ft

Front bumper

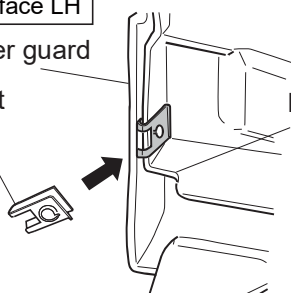

- (2) Insert the ⑥ J nut into the Front bumper as shown in Fig 5.

Align ⑥ J nut hole with the Front bumper guard hole.

- (1 places each for LH and RH, 2 places in total)

⚠ CAUTION

Insert the ⑥ J nut into the Front bumper body inside the bumper guard as shown in the diagram on the left (cross-section of the ⑥ J nut section).

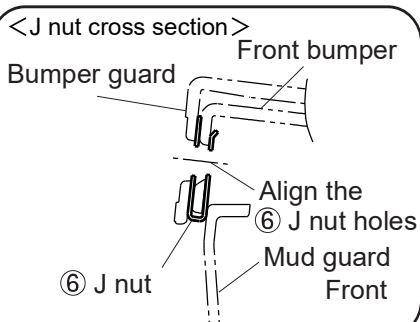

6

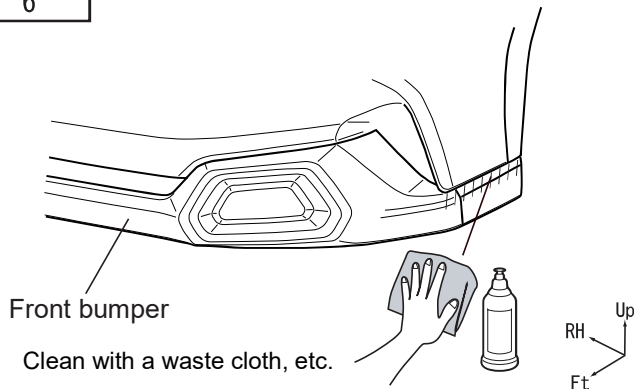

- (3) Clean, degrease, and dry the shaded area of the Front bumper with a degreasing agent.

⚠ CAUTION

If rainwater is attached, wipe it dry with a dry cloth.

Insufficient wiping and drying can cause the product to come off.

✳ Advice

- Clean the front bumper before work.
- Work indoors at a temperature of 15°C or higher.
- If the temperature is less than 15°C, please use a hair dryer to warm the adhesive surface and double-sided tape. (Guideline: 25-40°C)
- If air gets between the adhesive surface, the adhesive strength will weaken.
Make sure to crimp it thoroughly.
- Please avoid washing your car for 24 hours after pasting.

3. Installation of Front Spoiler

7

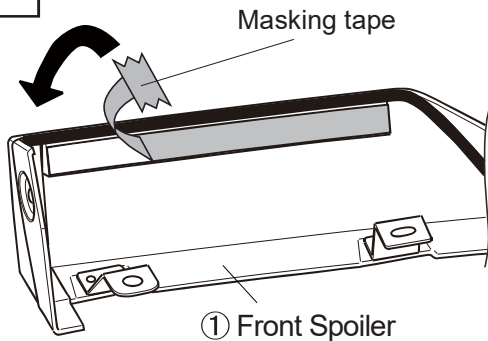

- (1) Peel off about 30mm of the release paper from double-sided tape attached to the ① Front spoiler, fold it back to the surface, and then attach it to the product surface using masking tape, etc., as shown in Fig 7.

⚠ CAUTION

Do not remove the release paper more than necessary.

The double-sided tape clings to the peripheral parts, which makes it difficult to position them.

8

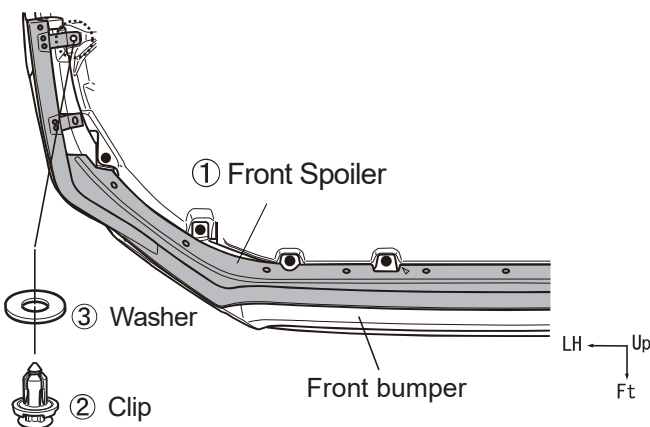

- (2) As shown in Fig 8, align the ① Front spoiler to the Front bumper and secure the rear end of the vehicle with the ③ Washer and ② Clip.

(1 places each for LH and RH, 2 places in total)

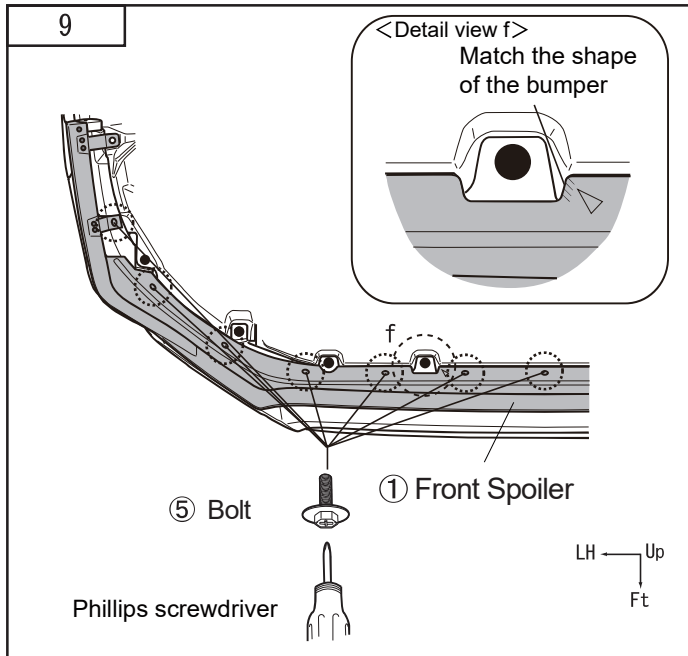

(3) As shown in Fig 9, align the shaded part (△ mark) of the ① Front spoiler with the shape of the Front bumper, and temporarily tighten ⑤ Bolt.

(1 place in the center
6 places each for LH and RH
13 places in total)

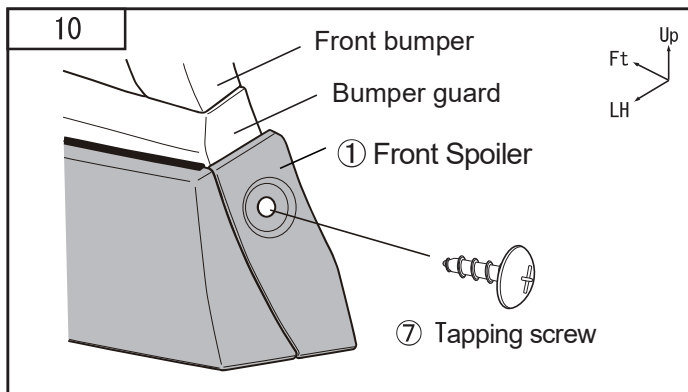

(4) As shown in Fig 10, temporarily tighten the wheel arch with the tapping ⑦ Tapping screw.

(1 places each for LH and RH, 2 places in total)

※Advice

If you do not have a Low head Phillips screwdriver, steer the front tire when working.

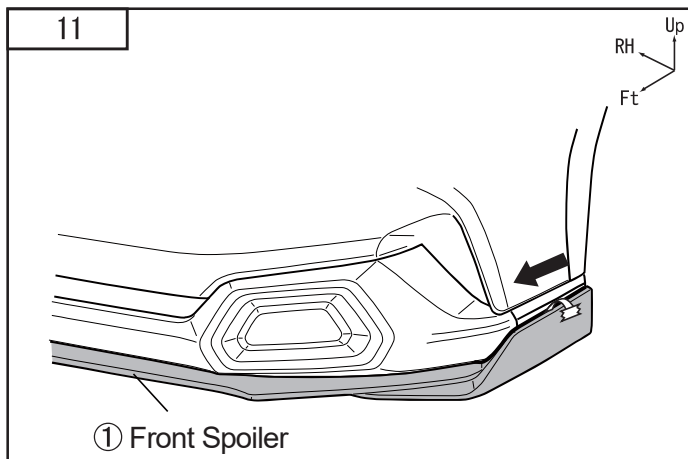

(5) As shown in Fig 11, press the double-sided tape while slowly pulling out the release paper in the direction of the arrow so as not to tear it in the middle.

When pulling out the release paper, be careful not to get ① Front spoiler molding caught between it and the Front bumper.

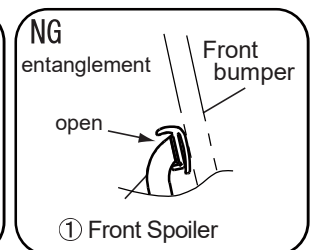
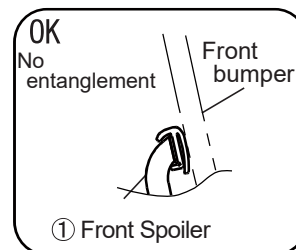

⚠ CAUTION

If it is difficult to remove the release paper, slowly pull it out with needle-nose pliers.

(6) Press the adhesive part of the double-sided tape with enough force to shake the car. (50N or more)

※How to correct when the mall is involved

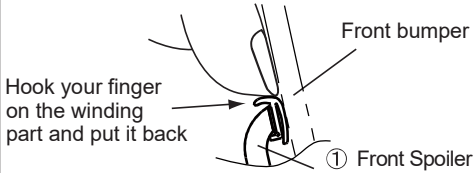

- If the molding gets involved, please fix it while paying attention to the damage to the bumper and peeling of the double-sided tape.
- If you fix it by hooking your finger on the winding part, it will return to the normal position.

12

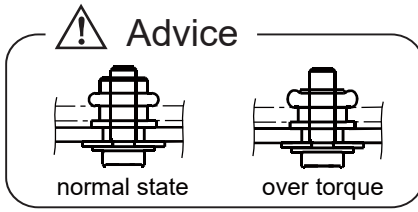
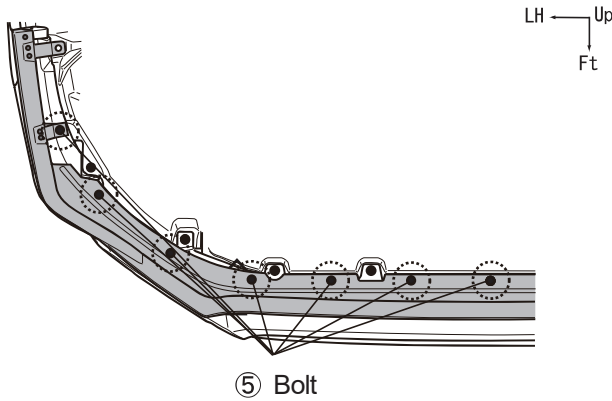

(7) Fully tighten ⑤ Bolt that were temporarily tightened in step (3).
Tightening torque: 1.0N·m (0.1kgf·m)

(1 place in the center
6 places each for LH and RH
13 places in total)

⚠ CAUTION

- Reference tightening torque 1.0N·m (0.1kgf·m)
- Please be careful not to overtorque.
- Doing so may cause ④ Wellnut to break or fall off.

13

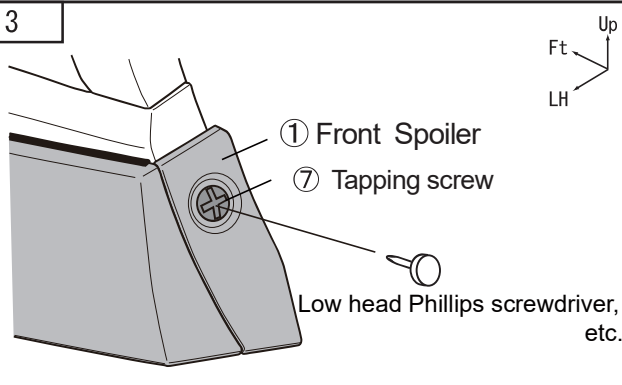

(8) Fully tighten ⑦ Tapping screw that was temporarily tightened in step (4).
Reference tightening torque: 2.0N·m (0.2kgf·m)

※Advice

If you do not have a Low head Phillips screwdriver, steer the front tire when working.

(9) Check the mounting part for lifting or tilting, check that there are no missing clips or bolts, or forget to tighten them, and finally check that there are no scratches or dirt.

This is the end of the work.

Revised contents

△	Details of the work	Date
00	Newly created document	30 / Oct / 2023