



SUBARU

Name : SIDE STRAKE SET
Part No. : E2610FJ050##

IMPREZA

Installation manual

Component parts

No.	Part name	Quantity
①	Side Strake RH	1
②	Side Strake LH	1
③	J-Nut (for Plastic)	2
④	Screw (M5×20mm)	2
⑤	Washer	2
⑥	Push Rivet	2
⑦	Installation Instruction	1

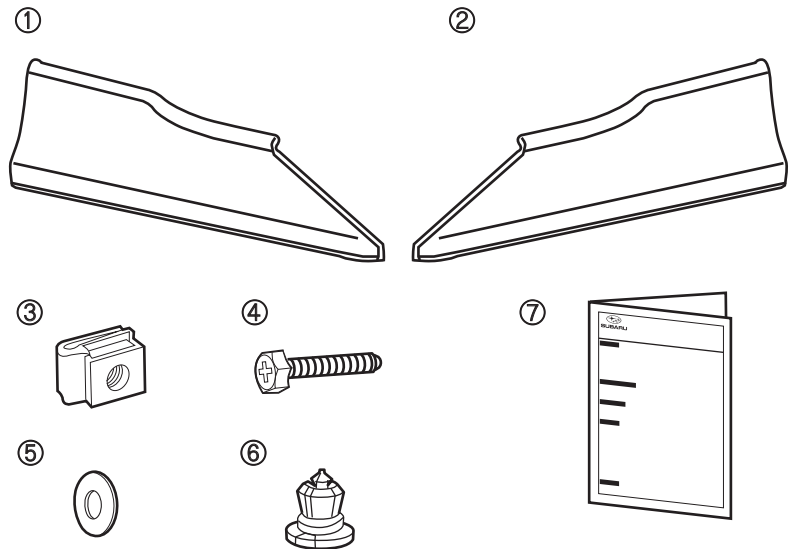

Tools

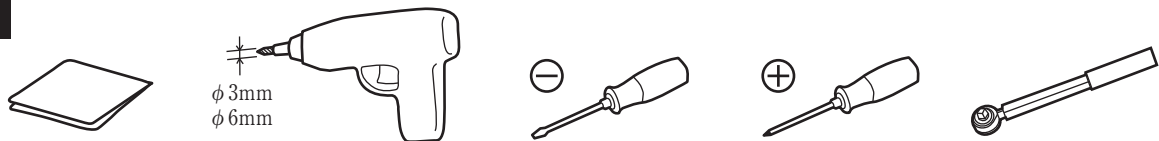

Important notes

If the surface temperature is below 60°F(15°C) heat the double sided tape and side under spoiler surface to a temperature of 77°F – 104°F(25°C – 40°C).

Liegt die Klebstoffoberflächentemperatur unter 60°F(15°C), doppelseitiges Klebeband und seite unter spoiler eine Temperatur von 25°C – 40°C(77°F – 104°F) erwärmen.

Si la temperatura de la superficie es inferior a 60°F(15°C), caliente la cinta de doble cara y la superficie del lado bajo spoiler hasta una temperatura de 77°F – 104°F(25°C – 40°C).

Si la température de surface adhésive recommandée est inférieure à 60°F(15°C), chauffez le ruban adhésif double-face et la surface du cote sous becquet à une température de 77°F – 104°F(25°C – 40°C).

Se la temperatura della superficie è inferiore a 60°F(15°C), riscaldare il nastro biadesivo e la superficie del lato sotto spoiler ad una temperatura di 77°F – 104°F(25°C – 40°C).

Meaning of Characters



Remove



Install

T

Tightening Torque



Discard



Re-use

Work outline

1

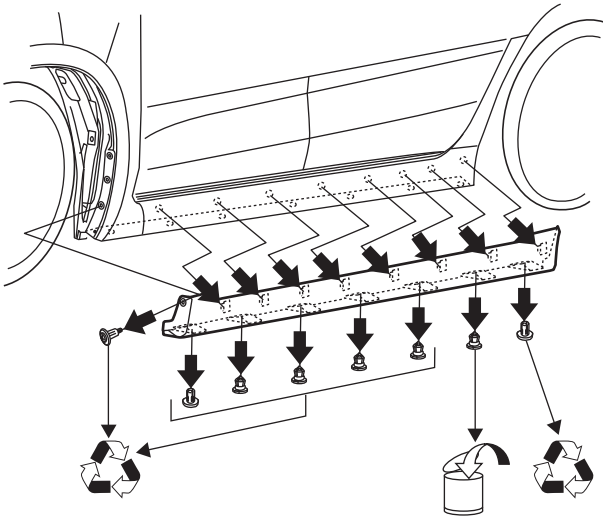

2

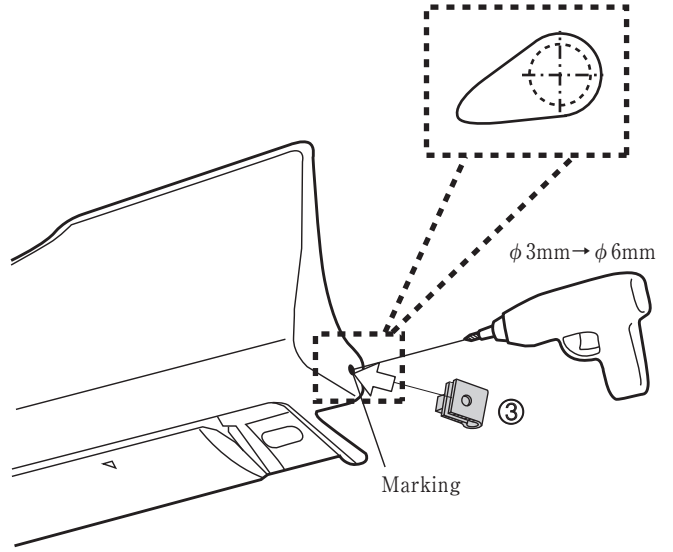

3

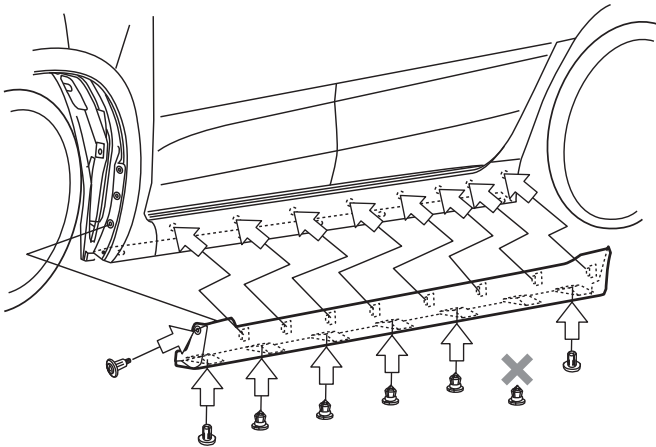

4

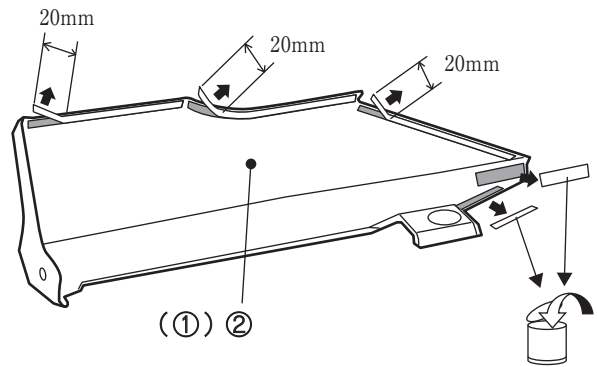

Peel off small sections of liner so they can be removed once the part is in position on the vehicle.

5

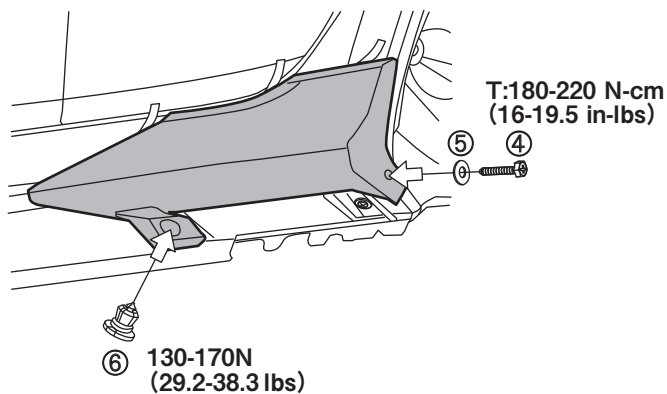

6

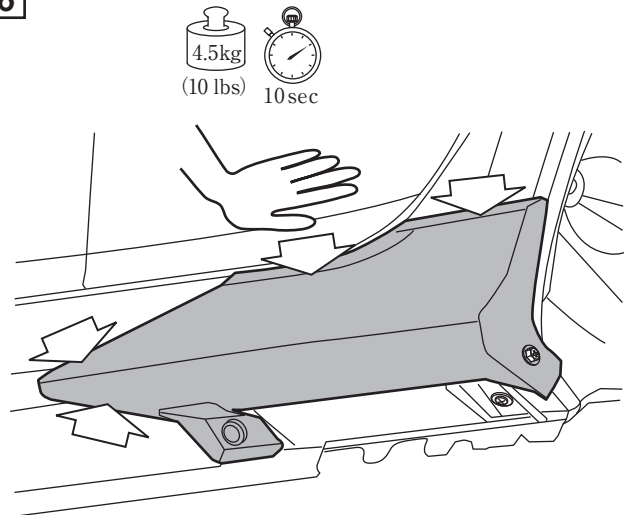

Completely remove tape liner and press firmly in the direction shown.