



FRONT BUMPER TRIM

Installation manual

Genuine SUBARU part numbers: E5510SL000 (Turquoise blue)
 E5510SL020 (Silver)
 Vehicle model: FORESTER 2025MY~

To installation worker

This manual describes how to install and handle FRONT BUMPER TRIM.

1. Before installation, be sure to read this manual for proper work.
2. The caution mark △ in this manual indicates important instructions. Strictly follow them.
3. SUBARU may not be held responsible for problems that occur due to your failure to follow this installation manual.

△ Important instructions

1. Before starting installation work, move the vehicle to a safe location.
2. To work safely, make sure that the vehicle does not move.
 (Make sure to apply parking brake.)
3. After turning the ignition off, disconnect the battery ground terminal.
4. Handle this product with care not to damage it or the vehicle.

Rev. No.	Revision content	Date
00	New establishment	2023/8/9

Completed installation sketch

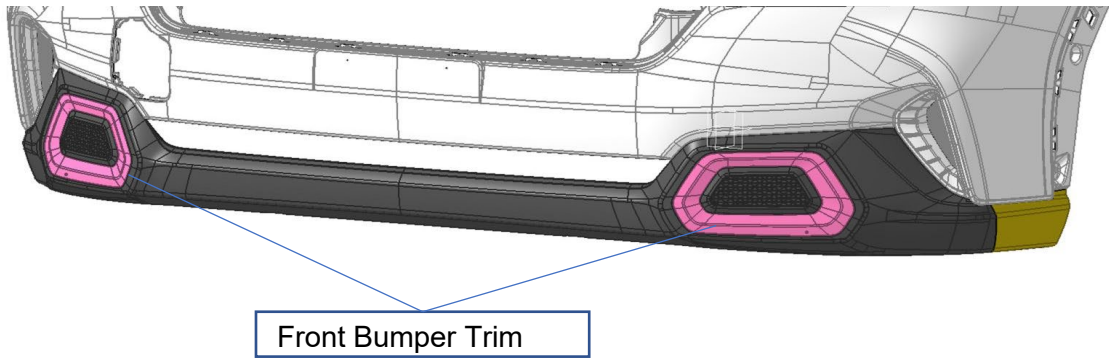

Component parts

■ E5510SL000 (turquoise blue) / E5510SL020 (silver)

No.	Item name	Qty
①	Front Bumper Trim RH	1
②	Front Bumper Trim LH	1

①

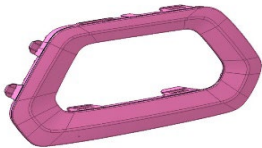

②

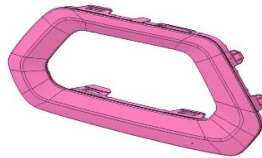

Tools required for work



Gloves

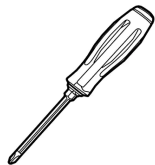

Phillips head
screwdriver



Plastic
remover

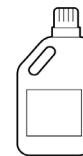

Cleaner
(Nonane is
recommended.)



Protective
tape

Work outline

Replacement of Front Bumper Molding

- ① Unpack the box and check that the product has no defect.
- ② Remove the front bumper. And then remove the bumper guard.
- ③ Replace the molding of the bumper guard with this product.
- ④ Install the bumper guard to the front bumper. And then install it to the vehicle.
- ⑤ After completing the above, check the appearance to ensure there is no scratch and such.

Work procedures

1. Remove the front bumper.

(1) To replace the molding with this product, remove the front bumper from the vehicle.

- Read the service manual to do this work.
- The removed parts are reused.
Be careful not to lose or damage them during work.
- Be careful of harness connectors including sensors.
If excessive load is applied to them, wire breakage or connector failure could occur.

2. Remove the bumper guard.

(1) To replace the molding with this product, remove the bumper guard from the bumper.

- ①. Remove the clips (one side: 3 places) that fasten the bumper guard side LH (RH).
- ②. Loosen the claws (one side: 3 places) and remove the bumper guard side LH (RH).
- ③. Remove the clips (one side: 2 places) that fasten the bumper guard.
- ④. Loosen the claws (18 places) and remove the bumper guard.

⚠ Important instructions

Without removing the bumper, you cannot access some screws that fasten the molding.

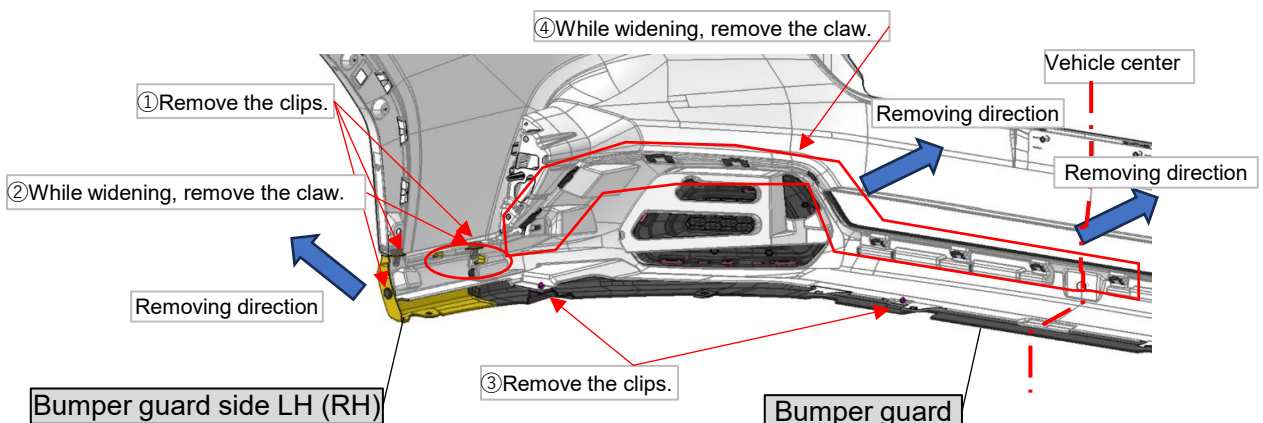

Fig. 2 Front bumper LH when seen from the back side

3. Replace the molding with this product.

- (1) Remove the screw (1 place) that fastens the molding to the bumper guard.
- (2) While widening the claw fitting portion (on bumper guard), remove the claws (8 places) on the molding from the vehicle inside.
(A plastic remover helps remove claws easily.)
- (3) After removing all the claws, install this product to the bumper guard.
Make sure that all the fitting portions are inserted.
- (4) After the replacement, fasten this product with the removed screws.
(Tightening torque: 0.8 N·m)

⚠ Important instructions

- The removed screws are used again. Be careful not to lose them.
- Be care not to damage the vehicle, this product, or surrounding parts.

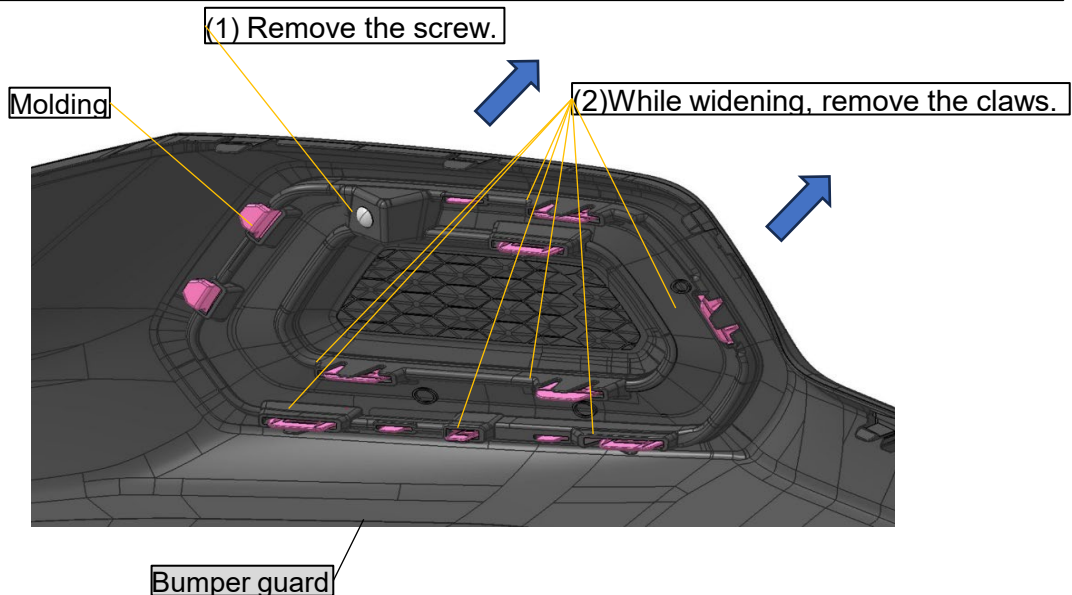

Fig. 3 Front bumper molding LH when seen from the back side

4. Install the bumper again.

- (1) Install the front bumper guard to the bumper.
- (2) Install the front bumper to the vehicle.
*Install them in the reverse order to removal.
*Be care not to damage the vehicle, this product, or surrounding parts.

5. Check after replacement completion

- (1) Make sure that there is no scratch on this product or surrounding areas, and that this product is surely installed.
- (2) Return the removed parts to the customer.
This is the completion of molding replacement.