



STI ROOF SPOILER

Installation instruction

Part No.	E7210FN010
Applicable model	CROSSTREK (GU) A TYPE~ IMPREZA (GU) A TYPE~

This manual describes how to install STI ROOF SPOILER.
Be sure to read this manual before installation to install correctly.

NOTES

1. Be sure to reflect the installation notes in this manual when installing. If you ignore the notes and install it, the product may come off or fall off, and it may interfere with the vehicle's functions.
2. Turn off the Ignition Switch and apply the Parking Brake before starting the installation work.
3. Please note that using thinner or the like on STI ROOF SPOILER may damage the surface.
Also, please be aware that if you bring fire close to it, it may deform.
4. When handling STI ROOF SPOILER, please be careful not to drop it.
5. Refer to the vehicle service manual for vehicle part removal and tightening torque.

TOOLS USED

- Ratchet Wrench
- Socket (8 mm,10 mm)
- Extension(100 mm)
- Torque Wrench
- Radio Pliers
- Masking Tape
- Waste Rag
- Scale
- Nonane

KIT CONTENTS

No.	Part Name	Quantity
①	STI ROOF SPOILER(Assembly part)	1

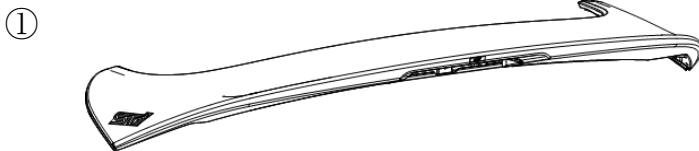

COMPLETION DRAWING

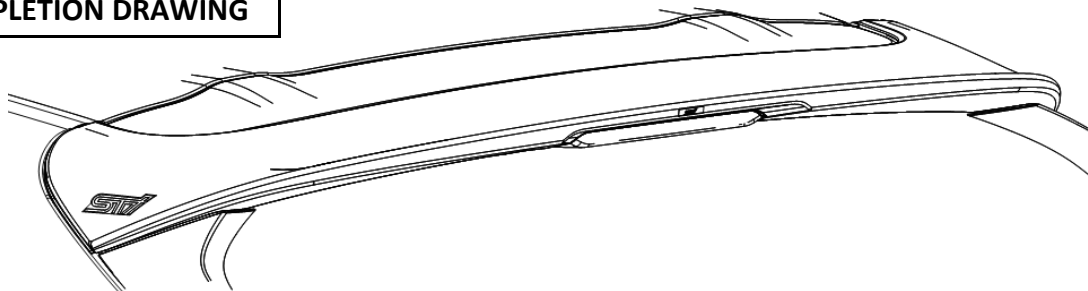

INSTALLATION PROCEDURE

Figure 1

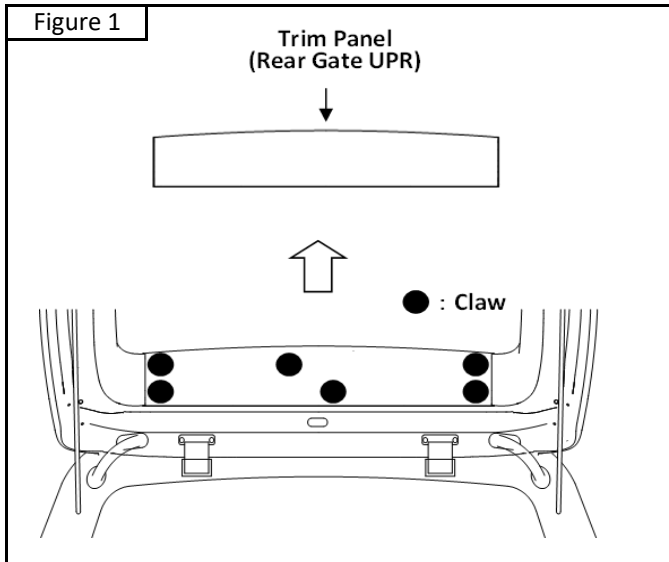

1. Open the Rear Gate and remove the Trim Panel. **【Figure 1】**

(1). Remove the claws on the terminal of the Trim Panel. (2 places on the left and right)

(2). Remove the claws in the center of the Trim Panel and remove the Trim Panel. (2 places)

Figure 2

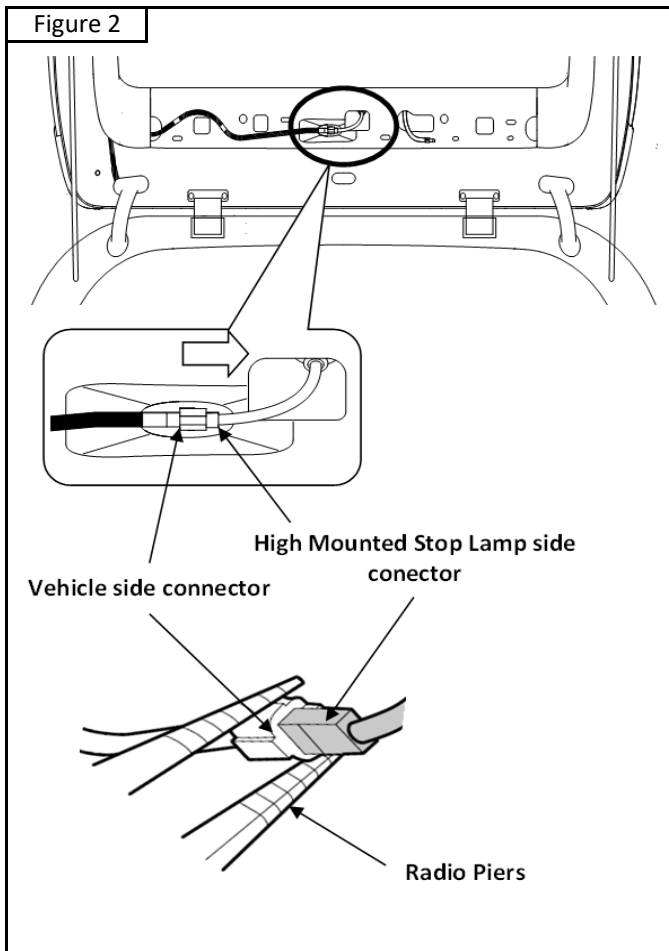

2. Remove the High Mounted Stop Lamp wiring connector. **【Figure 2】**

(1). Wrap Masking Tape around the tip of Radio Pliers.

(2). Pinch the connector and bend it until the locking claw no longer catches.

(3). Disconnect the connector when the locking claw no longer catches.

⚠ NOTES

- Please note that if the pinching force of the Radio Pliers is too large, the connector will be difficult to separate.
- Be careful not to hurt your hand with the edge of the sheet metal.

Figure 3

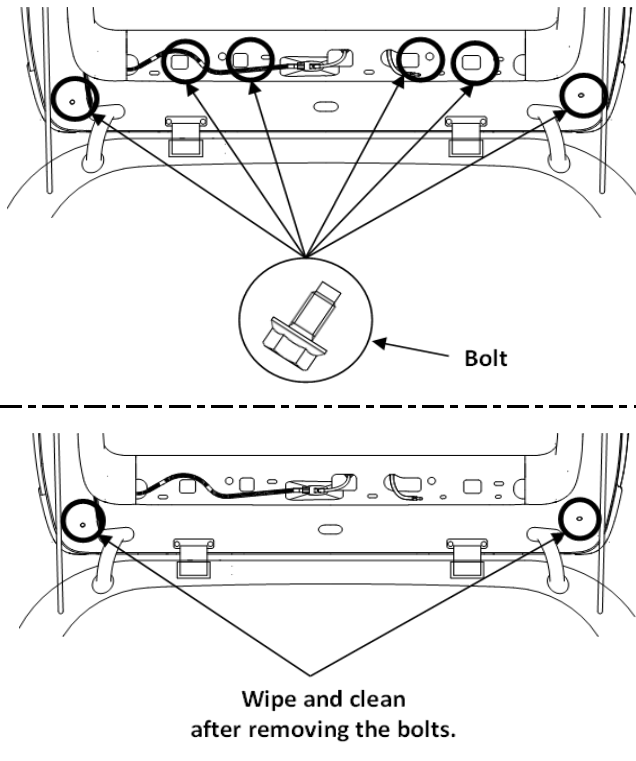

3. Remove the Spoiler installing bolts from the indoor side. 【Figure 3】

(1). Remove the bolts with Ratchet Wrench and Socket(10 mm). (6 places)

! NOTES

- Be careful not to drop the bolts inside the Rear Gate.
- The removed bolts will be used again, so keep them organized so that they will not be lost.
- Use Extension(100 mm) to remove bolts.
- The outermost installing parts may become dirty after removing the bolts. In the case, wipe and clean with a Waste Rag and Nonane.

Figure 4

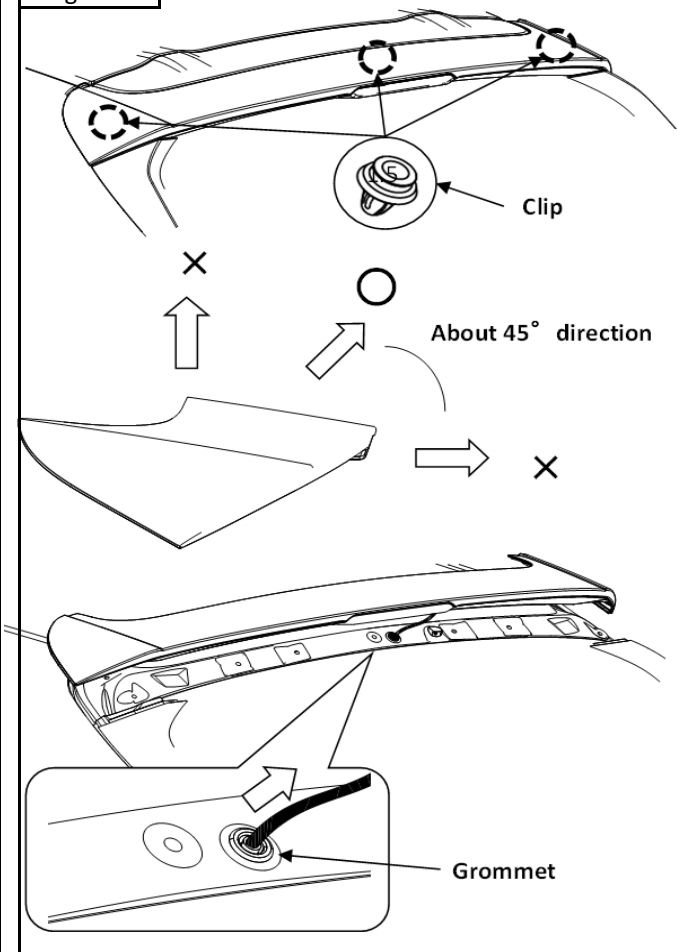

4. Close the Rear Gate and remove the Spoiler from the Rear Gate. 【Figure 4】

(1). The clips are fixed on the Spoiler side. Pull the Spoiler diagonally upward (about 45° direction) to remove the clips from the Rear Gate. (3 places)

(2). Remove the wiring grommet from the Rear Gate.

(3). Remove the Spoiler from the Rear Gate.

! NOTES

- Be careful not to pinch your fingers when opening and closing the Rear Gate.
- When removing the clips, be careful not to damage the Spoiler by hitting it against the vehicle body.
- After removing the Spoiler, wipe off the dirt on the removal surface with a Waste Rag.

Figure 5

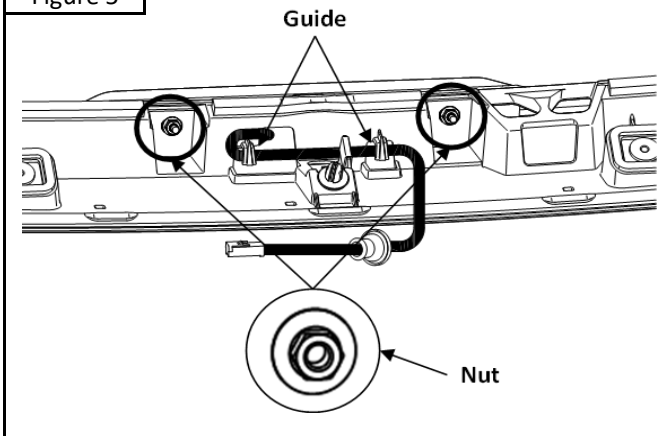

5. Remove the High Mounted Stop Lamp from the removed Spoiler. **【Figure 5】**

- (1). Remove the wiring from the guide.
- (2). Remove the nuts with Ratchet Wrench and Socket(8 mm). (2 places)
- (3). Remove the High Mounted Stop Lamp.

! NOTES

- The removed nuts will be used again, so keep them organized so that they will not be lost.

Figure 6

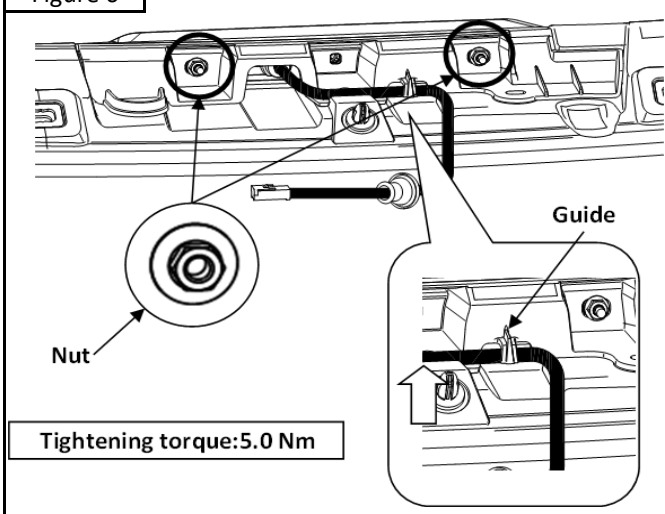

6. Install the High Mounted Stop Lamp to STI ROOF SPOILER. **【Figure 6】**

- (1). Fit the High Mounted Stop Lamp in STI ROOF SPOILER.
- (2). Temporarily tighten the nuts with Ratchet Wrench and Socket(8 mm). (2 places)
- (3). Adjust the position of the High Mounted Stop Lamp so that the gap between STI ROOF SPOILER and the High Mounted Stop Lamp is even on the left and the right. **【Figure 7】**

Figure 7

Adjust the position so that the gap between STI ROOF SPOILER and the High Mounted Stop Lamp is even on the left and the right.

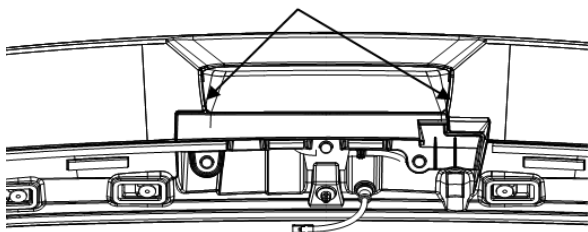

- (4). Securely tighten the nuts with Ratchet Wrench and Socket(8 mm). (2 places)

Tightening torque : 5.0 Nm

- (5). Hook the High Mounted Stop Lamp wiring on the guide about 120 mm from the grommet. **【Figure 6】 【Figure 8】**

Figure 8

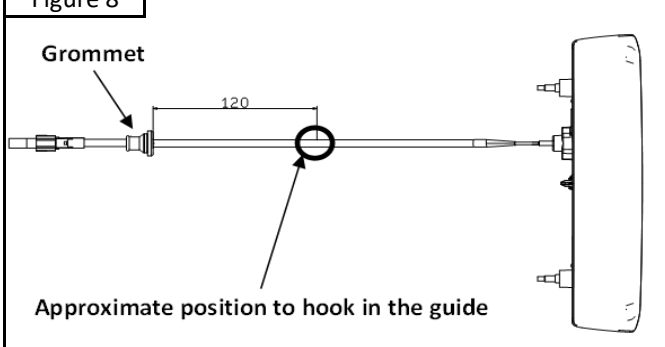

! NOTES

- Be careful not to crush the High Mounted Stop Lamp wiring between STI ROOF SPOILER and the vehicle body when installing.

Figure 9

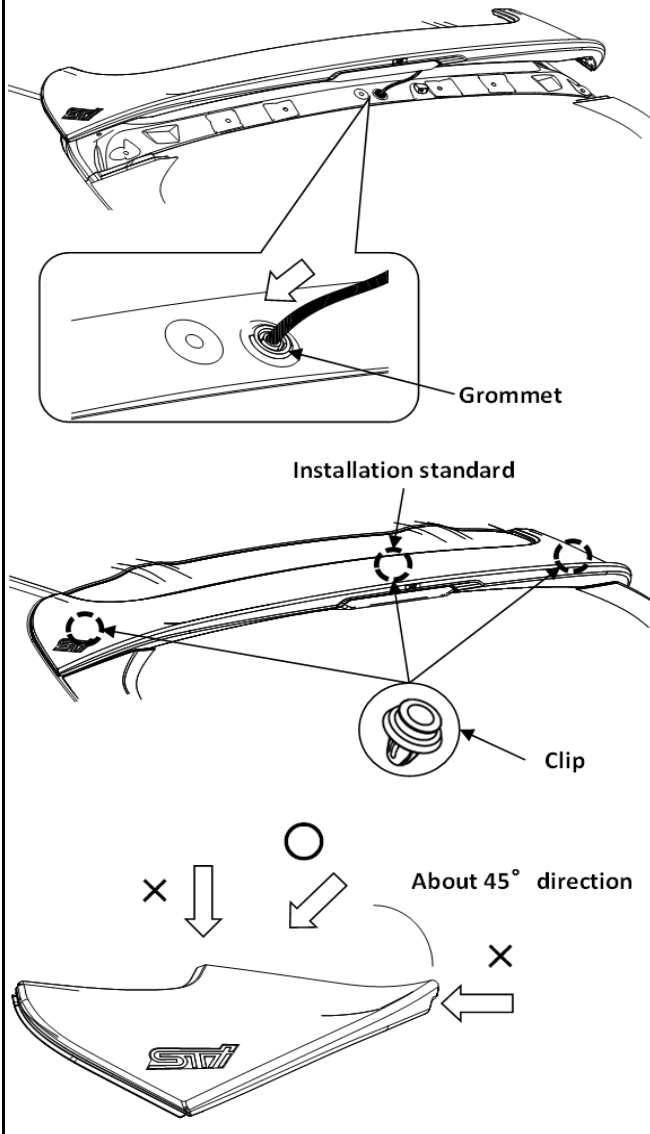

7. Install STI ROOF SPOILER to the Rear Gate. 【Figure 9】

- (1). Install the wiring grommet to the Rear Gate.

⚠ NOTES

- Be careful not to let STI ROOF SPOILER hit the vehicle body and damage them.
- Make sure the grommet is firmly attached to the rear gate without any gaps.

- (2). Apply STI ROOF SPOILER to the Rear Gate using the clips as a reference.

- (3). Push in STI ROOF SPOILER diagonally downward (about 45° direction) to install the clips to the Rear Gate. (3 places)

Figure 10

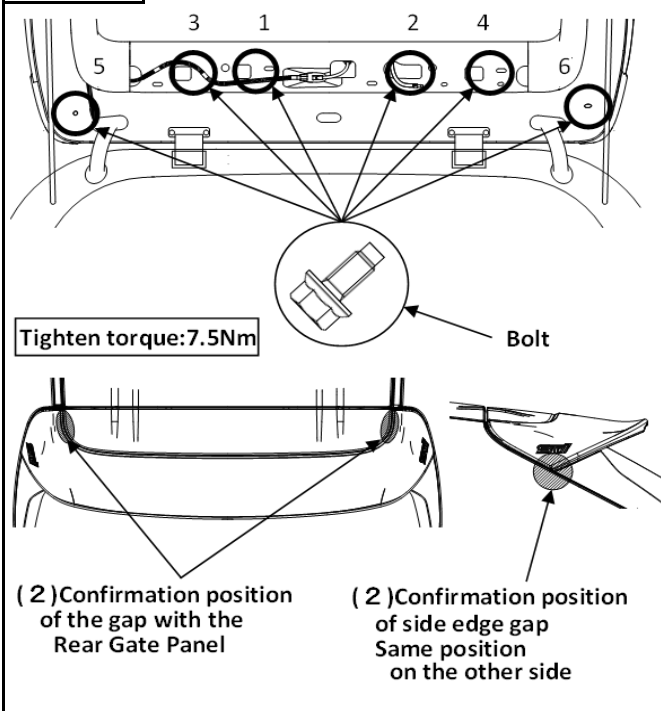

8. Open the Rear Gate and tighten the bolts from the indoor side. 【Figure 10】

- (1). Temporary tighten the bolts with Ratchet Wrench and Socket (10 mm). (6 places)

⚠ NOTES

- Be careful not to drop the bolts inside the Rear Gate.

- (2). Make sure the gaps between the terminals on both sides and the Rear Gate Panel are even on the left and right.

- (3). Tighten the bolts securely with Torque Wrench (10 mm) in the order shown in the figure. (6 places)

Tighten torque : 7.5 Nm

Figure 11

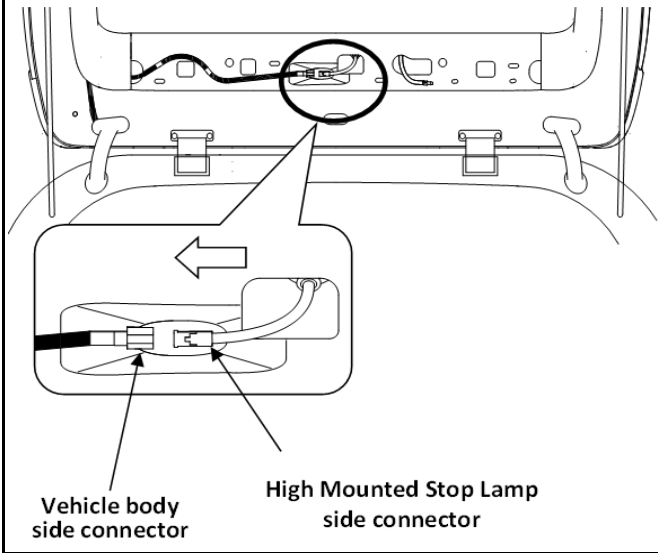

- (4).Connect the High Mounted Stop Lamp side connector to the vehicle body side connector. 【Figure 11】
- (5).Open and close the Rear Gate and make sure STI ROOF SPOILER is securely connected.
- (6).Close the Rear Gate, shake STI ROOF SPOILER lightly by hand, and make sure there is no backlash.

Figure 12

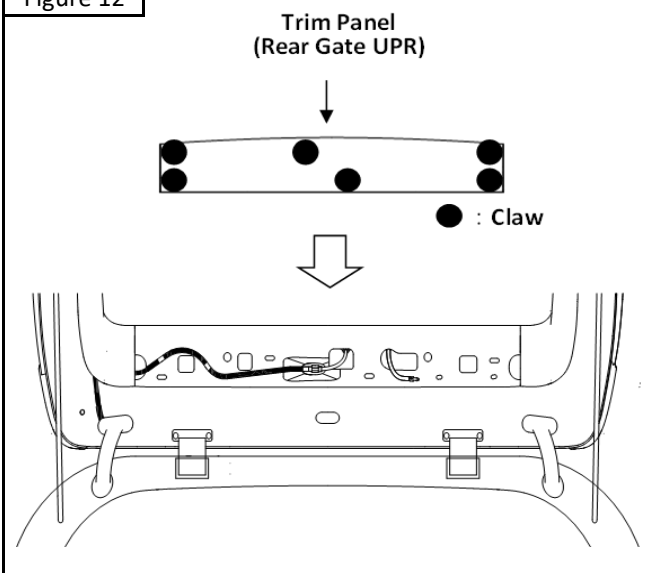

- 9 . Open the Rear Gate and restore the Trim Panel. 【Figure 12】
- (1).Install the claws in the center of the Trim Panel to the Rear Gate. (2 places)
- (2).Install the claws on the terminal of the Trim Panel. (2 places on the left and right)

! NOTES

- After the installation is complete, make sure that the High Mounted Stop Lamp is lit.

This is the end of the work.

REV No.	DATE	CONTENTS
Δ00	'22.11.07	Newly created document
Δ01	'23.02.20	Additional applicable model
Δ02	'23.04.11	Additional Figure and Notes