



PART NUMBER : E721SFG200XX

INSTALLATION INSTRUCTIONS

DESCRIPTION : IMPREZA

REAR SPOILER ASSY

A KIT CONTENTS

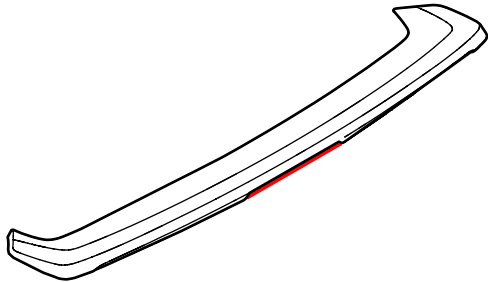

B

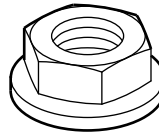

5X

C



1X

D



1X RH



1X LH

E

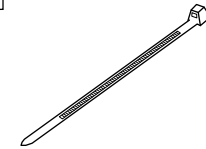

1X Wire Tie

F

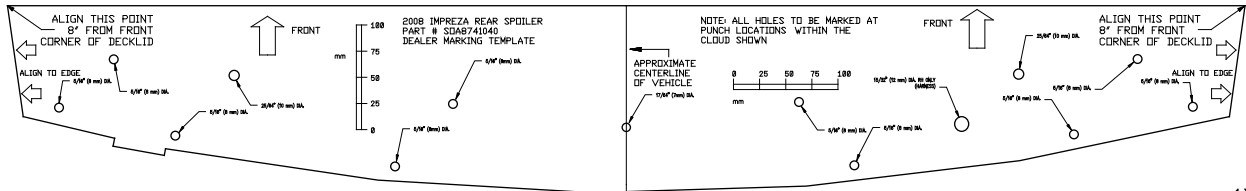

TOOLS REQUIRED:

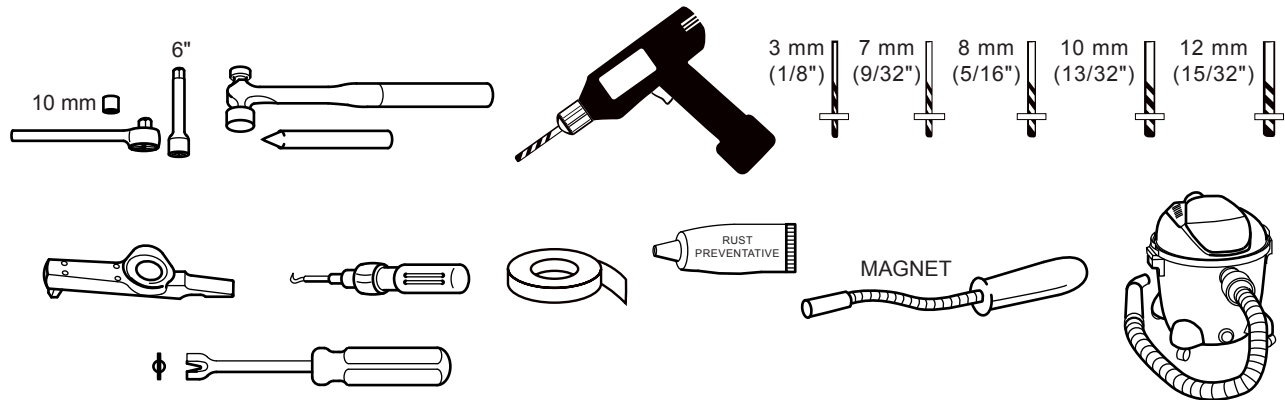

Meaning of Characters:



: Install



: Connect



: Remove



: Location of clip or screw



: Do Not Discard

T

: Tightening Torque



: Re use

PART NUMBER
E721SFG200XX

ISSUE
01

DATE
05/29/2007

SUBARU OF AMERICA

PAGE
1/6

REAR SPOILER ASSEMBLY

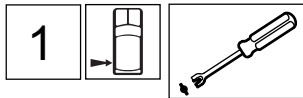

1) Remove deck lid carpet panel by removing 14 push pins.

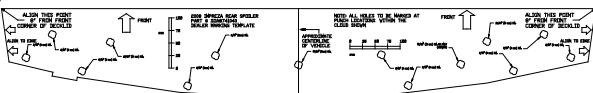
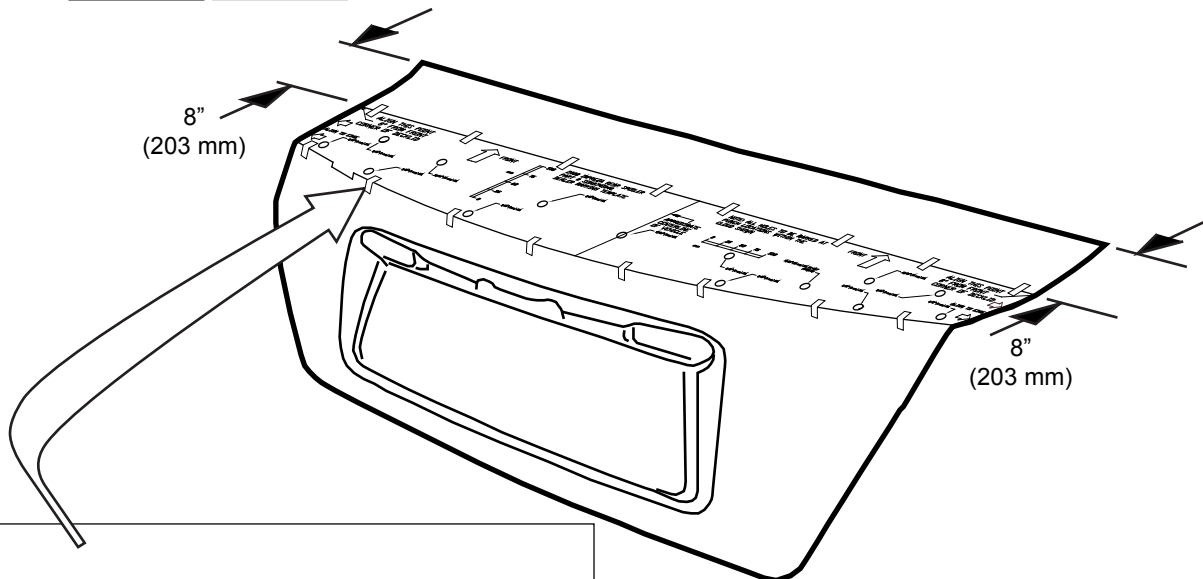
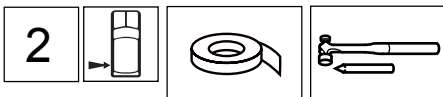
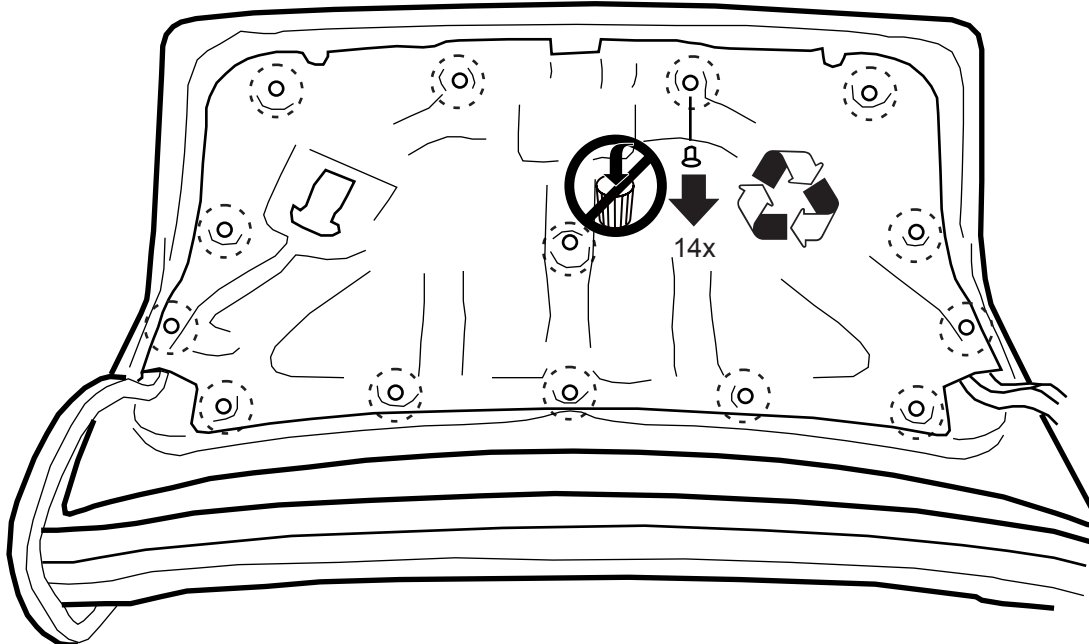

PART NUMBER
E721SFG200XX

ISSUE
01

DATE
05/29/2007

SUBARU OF AMERICA

PAGE
2/6

REAR SPOILER ASSEMBLY

3



3 mm
(1/8")

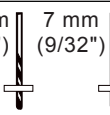

7 mm
(9/32")

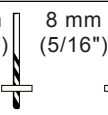

8 mm
(5/16")

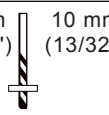

10 mm
(13/32")

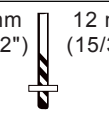

12 mm
(15/32")

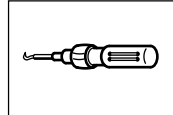
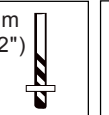

MAGNET

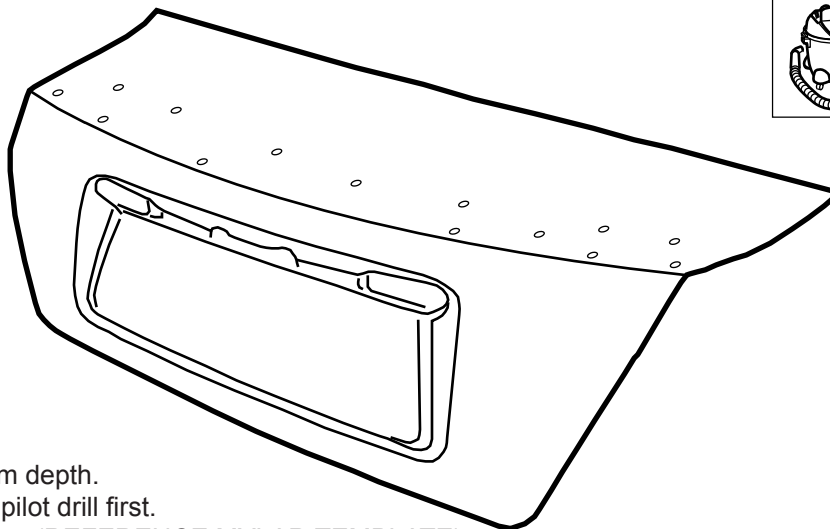
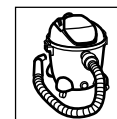
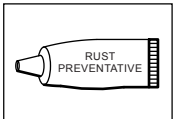

PROCEDURES:

- 1) Set all drill stops to 1/4" or 6mm depth.
- 2) Drill all 14 locations with 3mm pilot drill first.
- 3) Open all holes to final dimension (REFERENCE MYLAR TEMPLATE).
- 4) Remove all metal chips with vacuum and magnet.
(USE CAUTION NOT TO SCRATCH THE VEHICLE PAINT SURFACE).
- 5) Remove all burrs from holes and apply rust preventative.

4



- 1) Check alignment of plastic holding clips.
- 2) Check to make certain electrical cable will not be pinched between spoiler mounting surface and deck lid.
- 3) Apply firm downward force at eight clip locations.
- 4) Audible "click" should be heard at each clip location to indicate engagement.

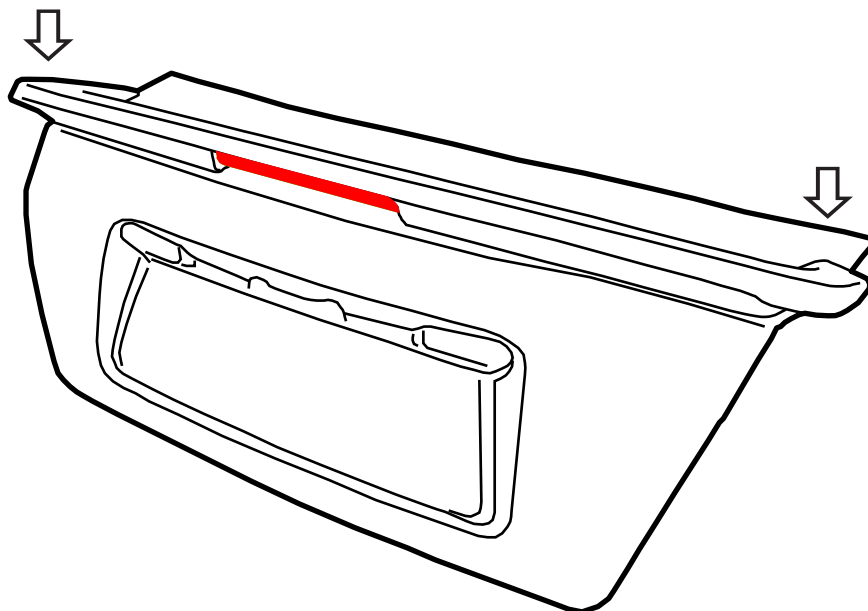

REAR SPOILER ASSEMBLY

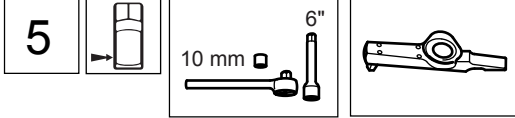

T - 5.1 +/- .4 Nm
45 +/- 3 in lbs.
(3.75 ft. lbs.)

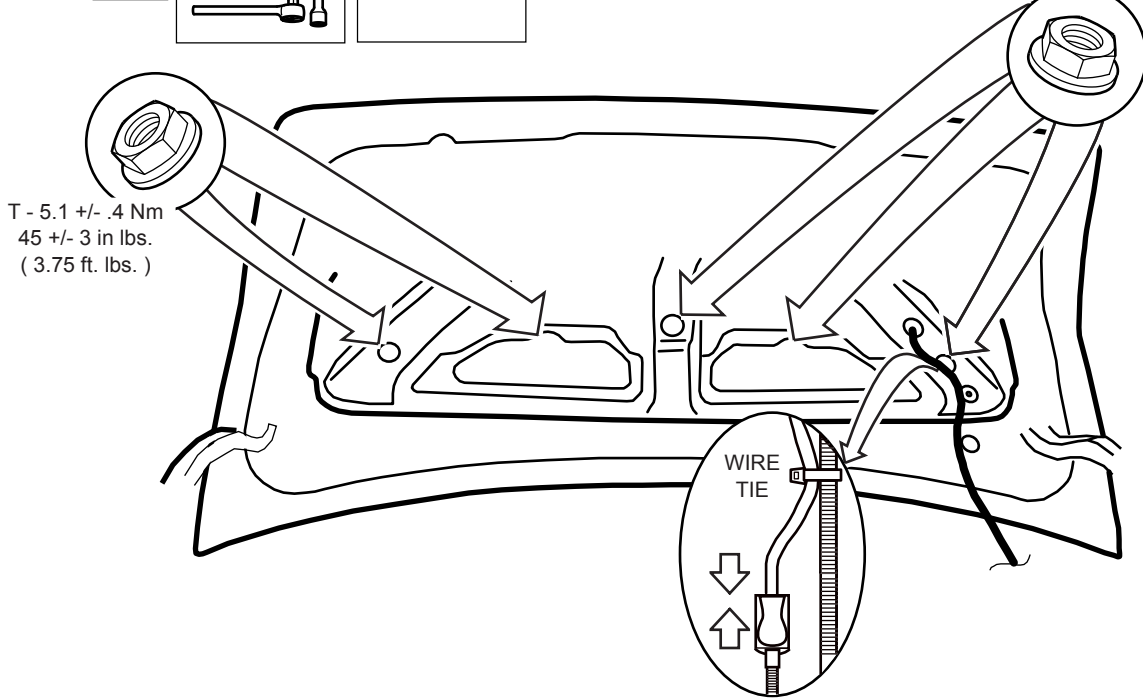

SPOILER HIGH MOUNT STOP LAMP WIRE HARNESS CONNECTION POINT

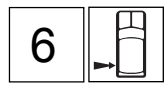

1) Re-install deck lid carpet panel with the 14 recycled push pins.

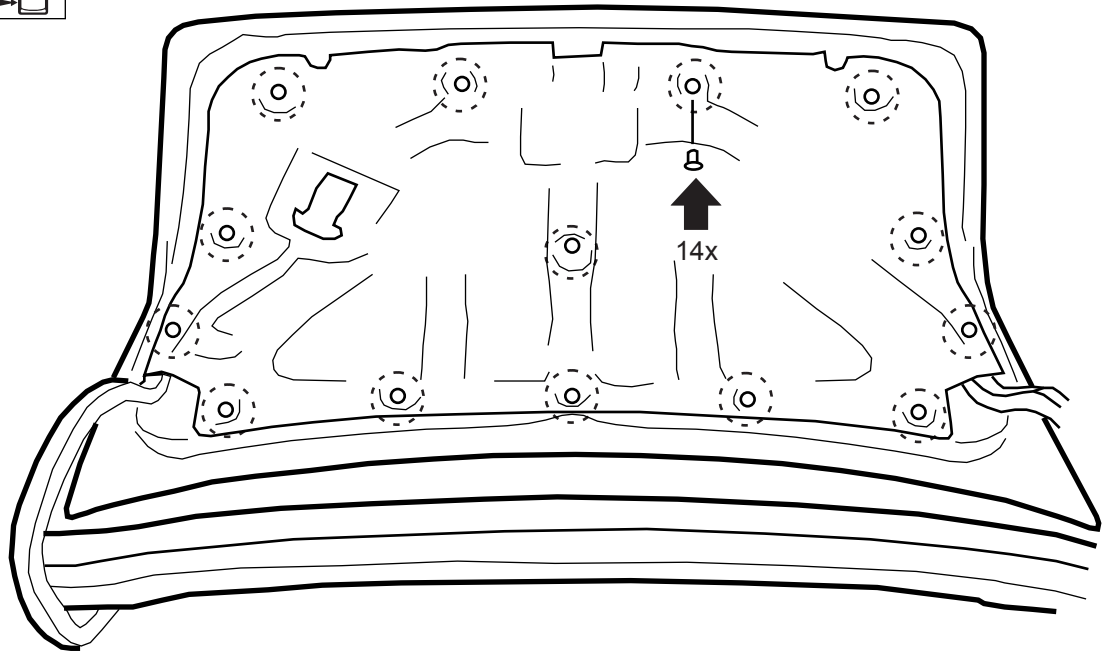

REAR SPOILER ASSEMBLY

7



CHECK THAT SPOILER HIGH MOUNT STOP LAMP PROPERLY ILLUMINATES WHEN BRAKE PEDAL IS DEPRESSED.

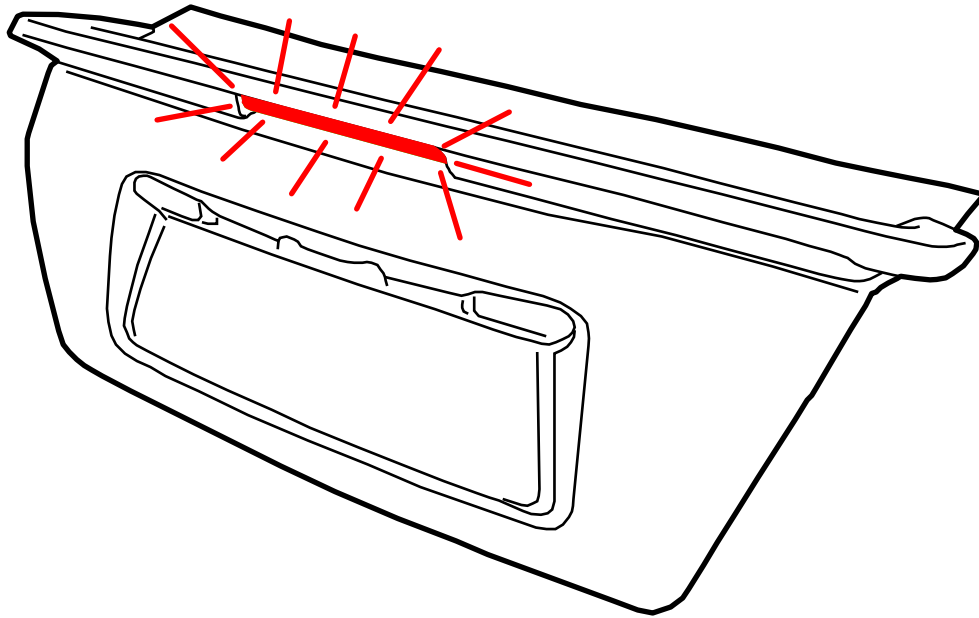

 **CHANGE THE TORSION BARS IN ACCORDANCE WITH THE FOLLOWING PROCEDURE.**

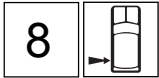

REMOVER NO.SOA321041
TORSION BAR RIGHT SOA8741020
TORSION BAR LEFT SOA8741010

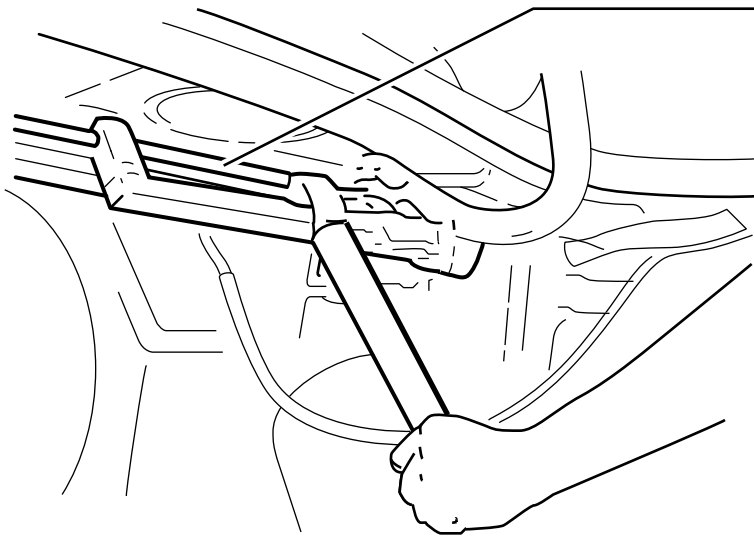

- 1) Open trunk lid, brace trunk in the open position. Remove torsion bars from the hinge links using remover tool (SOA321041).
- 2) Refer to illustration below for LH/RH identification.

CAUTION: TRUNK LID DROPS UNDER IT'S OWN WEIGHT
WHEN TORSION BARS ARE REMOVED.

- 3) Install the torsion bars using the remover in the reverse procedure of "removal".
TORSION BAR RIGHT PART NO. SOA8741020
TORSION BAR LEFT PART NO. SOA8741010

TORSION ROD SET-UP

