





INSTALLATION INSTRUCTIONS

PART NUMBER: F541SAL000

DESCRIPTION: MOONROOF AIR DEFLECTOR

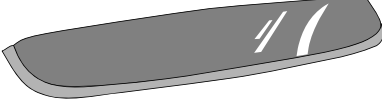
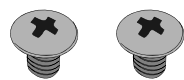
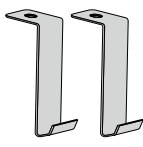
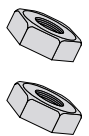
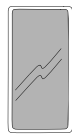
VEHICLE DESCRIPTION: Outback / Legacy / Impreza

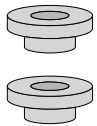
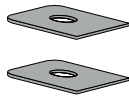
<p>A</p> 	<p>B</p>  <p>1x 2x</p>	<p>C</p>  <p>2x</p>	<p>D</p>  <p>2x</p>	
<p>E</p>  <p>2x</p>	<p>F</p>  <p>1x</p>	<p>G</p>  <p>2x</p>	<p>H</p>  <p>2x</p>	

Tools Required

Phillips head screwdriver

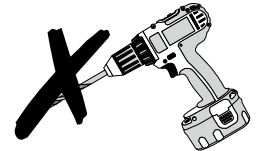
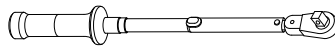

NO POWER TOOLS

Meaning of Characters:



:Remove

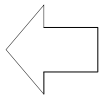

:Install



:Disconnect

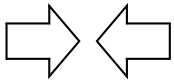

:Connect

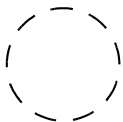

:Location of Clips or Screws

T

:Tightening Torque



:Loosen

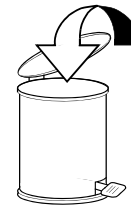

:Discard

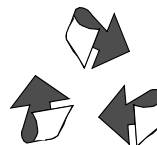

:Re - use

IMPORTANT NOTES

- DO NOT USE SOLVENT BASED CLEANERS ON MOONROOF AIR DEFLECTOR.
- DO NOT USE LOCTITE ON DEFLECTOR ATTACHING SCREWS.
- USE SOAP AND WATER ONLY TO CLEAN MOONROOF AIR DEFLECTOR.

The moonroof air deflector is designed to reduce wind noise when the moonroof is in the opened position. However, in some cases wind noise may be slightly louder with the moonroof in the tilt or closed position.

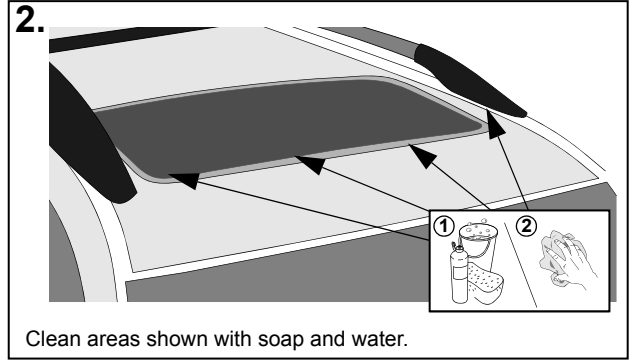
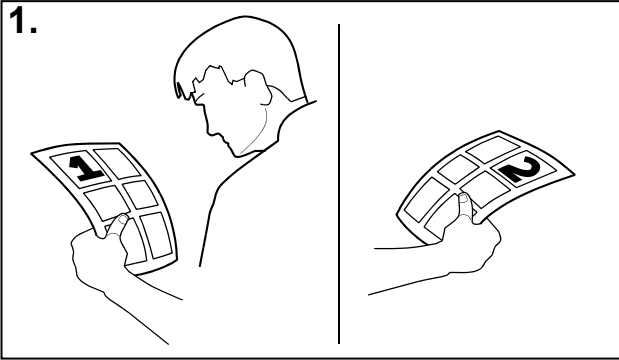

Clean areas shown with soap and water.

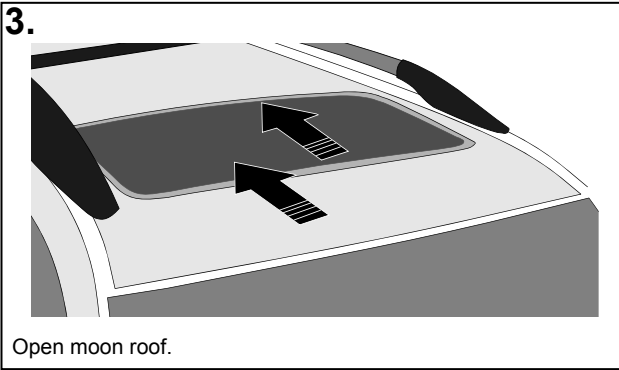

Open moon roof.

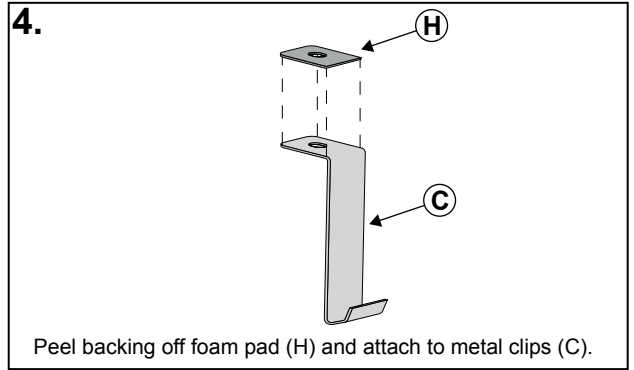

Peel backing off foam pad (H) and attach to metal clips (C).

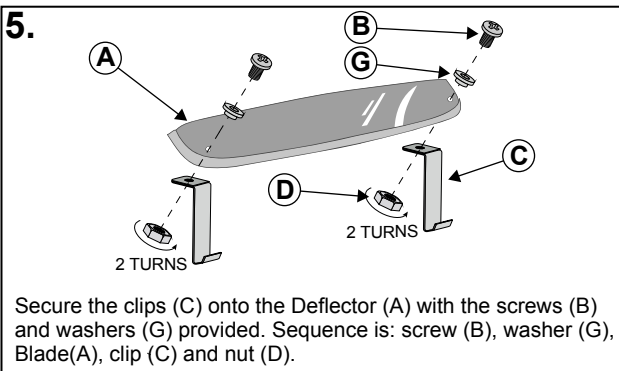

Secure the clips (C) onto the Deflector (A) with the screws (B) and washers (G) provided. Sequence is: screw (B), washer (G), Blade(A), clip (C) and nut (D).

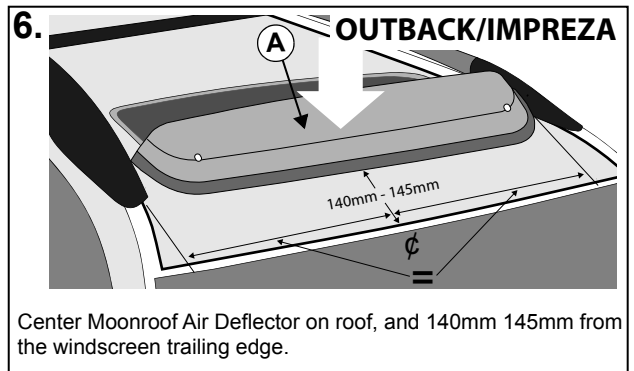

Center Moonroof Air Deflector on roof, and 140mm 145mm from the windscreen trailing edge.

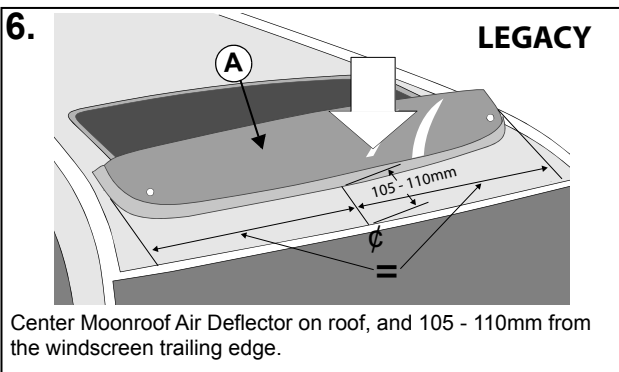

Center Moonroof Air Deflector on roof, and 105 - 110mm from the windscreen trailing edge.

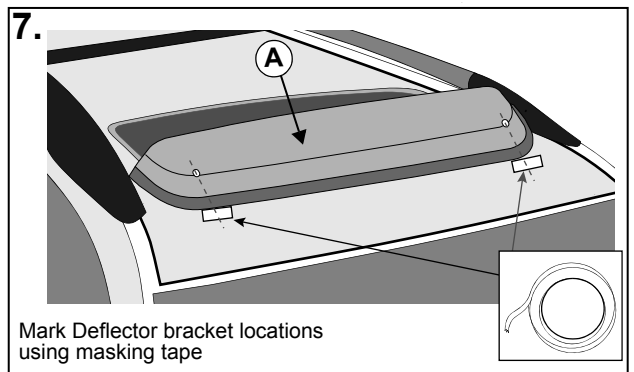

Mark Deflector bracket locations using masking tape

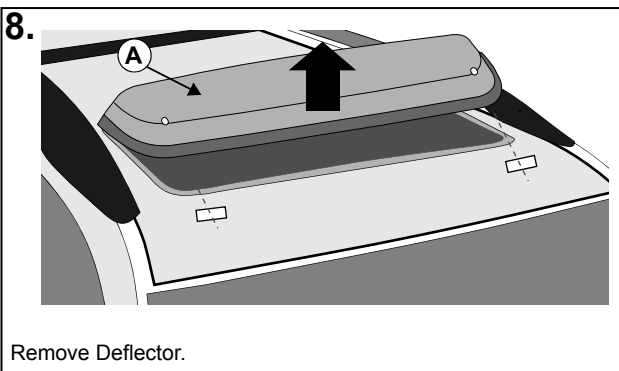

Remove Deflector.

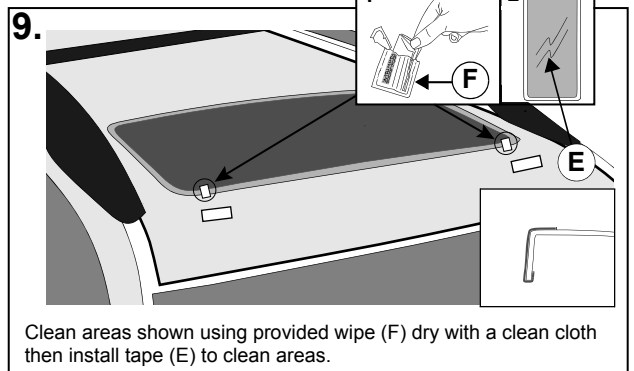

Clean areas shown using provided wipe (F) dry with a clean cloth then install tape (E) to clean areas.

10.

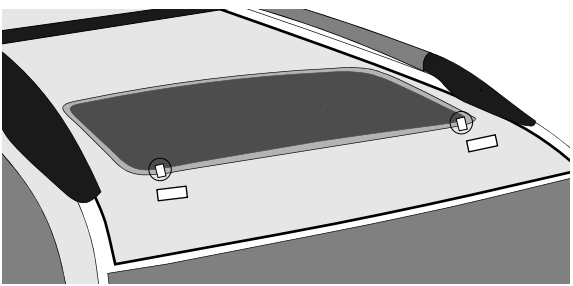

Remove masking tape.

11. **OUTBACK/IMPREZA**

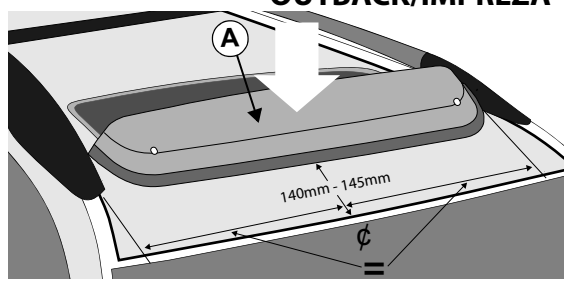

Center Moonroof Air Deflector on roof, and 140mm - 145mm from the windscreen trailing edge.

11. **LEGACY**

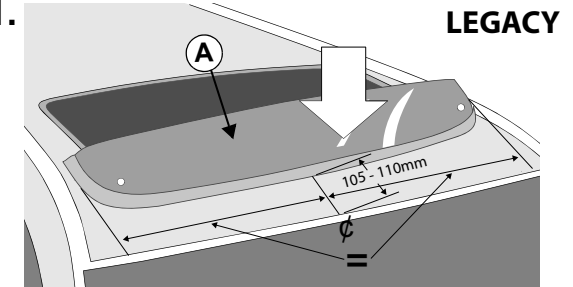

Center Moonroof Air Deflector on roof, and 105 - 110mm from the windscreen trailing edge.

13.

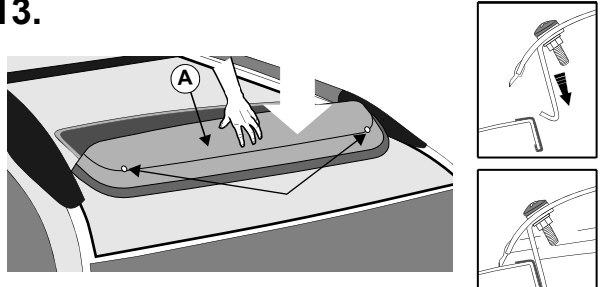

Push down gently on Deflector (A) so clips (C) hook under Moonroof sheet metal flange.

14.

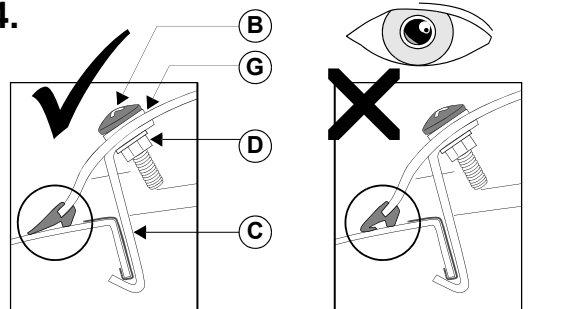

Before tightening, ensure the rubber seal is flat against the roof and not curling under itself.

15.

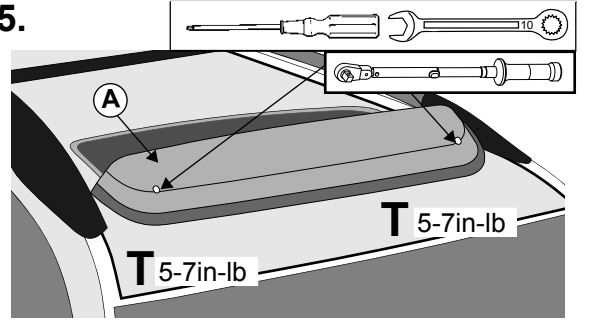

Tighten screws and nuts to secure Deflector to roof.

16.

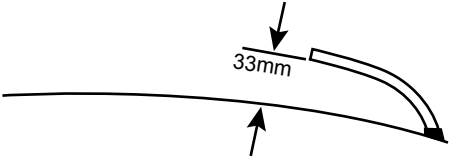

Moonroof Air Deflector should not exceed 33mm above moon roof glass at center. If moon roof Deflector is more than 33mm check for improper installation and ensure screws and nuts are tightened securely.

 **DO NOT USE** solvent based cleaners on Moonroof Air Deflector. **USE** soap and water only to clean Moonroof Air Deflector.

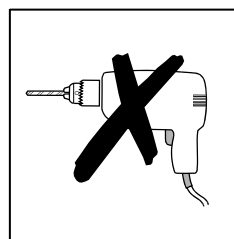



**INSTRUCTIONS
D'INSTALLATION**

NUMÉRO DE PIÈCE : F541SAL000

DESCRIPTION : DÉFLECTEUR D'AIR DE TOIT OUVRANT

DESCRIPTION DU VÉHICULE : Outback/Legacy/Impreza de SUBARU

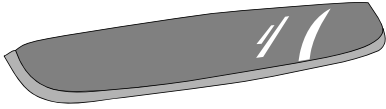
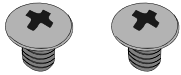
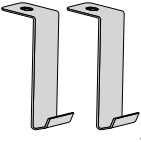
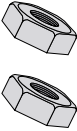
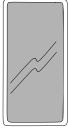
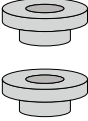
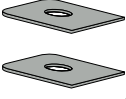
A	 1x		B	 2x	C	 2x	D	 2x	
E	 2x	F	G	 2x	H	 2x			

Outils requis

Tournevis Phillips

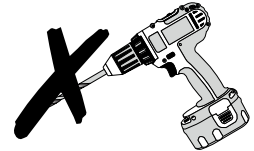
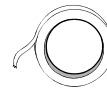
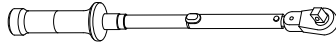

AUCUN OUTIL ÉLECTRIQUE

Signification des symboles :



: Enlever

T

: Couple de serrage

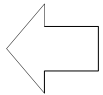

: Poser



: Desserrer



: Déconnecter

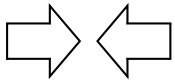

: Connecter

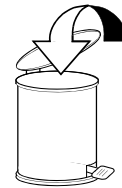

: Jeter

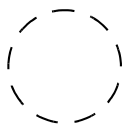

: Emplacement des attaches ou vis

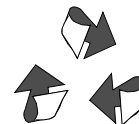

: Réutiliser

REMARQUES IMPORTANTES
 • N'UTILISEZ PAS DE NETTOYANT À SOLVANT SUR LE DÉFLECTEUR D'AIR DU TOIT OUVRANT.
 • N'UTILISEZ PAS DE FREIN FILETS (LOCTITE) SUR LES VIS DU DÉFLECTEUR D'AIR.
 • UTILISEZ UNIQUEMENT DU SAVON ET DE L'EAU POUR NETTOYER LE DÉFLECTEUR D'AIR.

Le déflecteur d'air est conçu pour réduire le bruit de vent quand le toit ouvrant est en position ouverte. Toutefois, dans certains cas, le bruit peut être un peu plus fort si le toit est ouvert en inclinaison ou s'il est fermé.

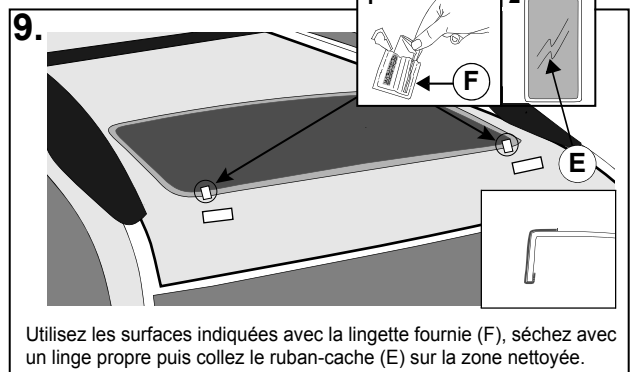
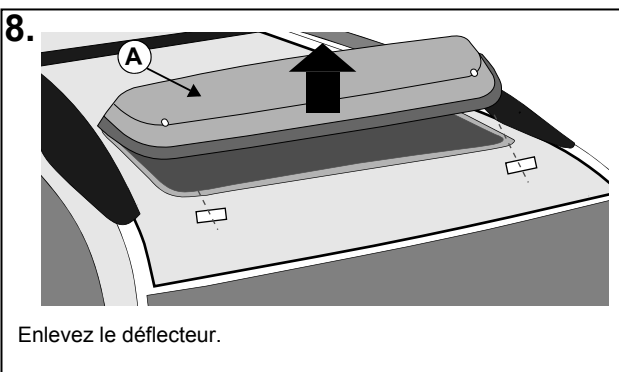
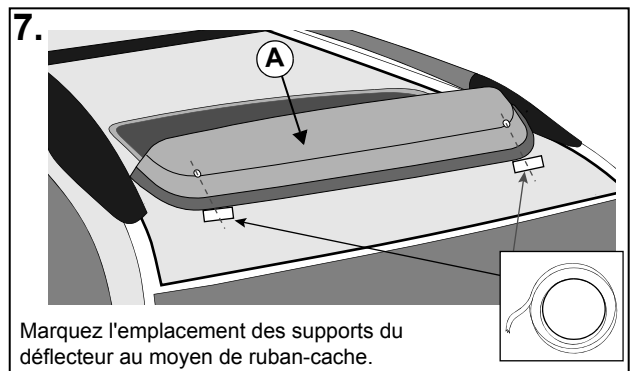
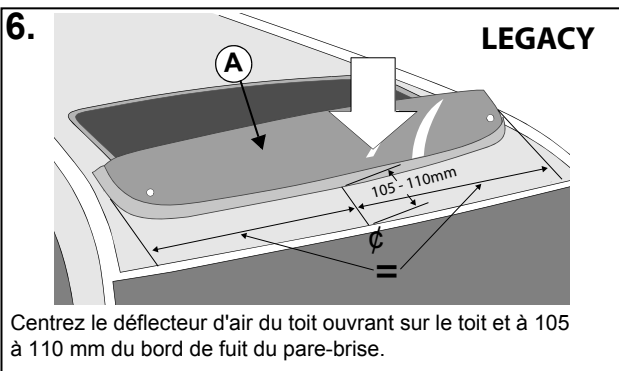
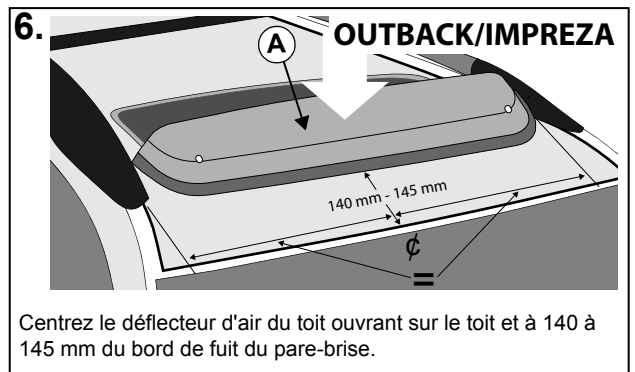
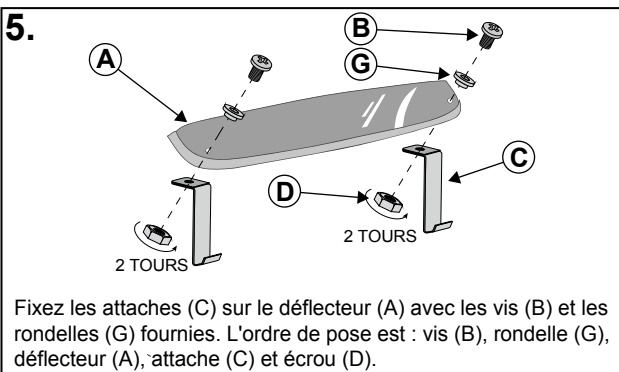
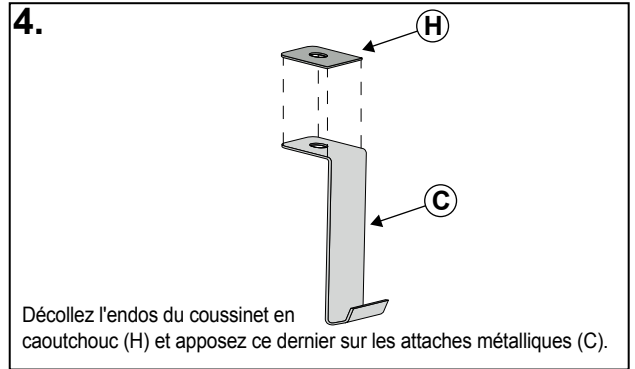
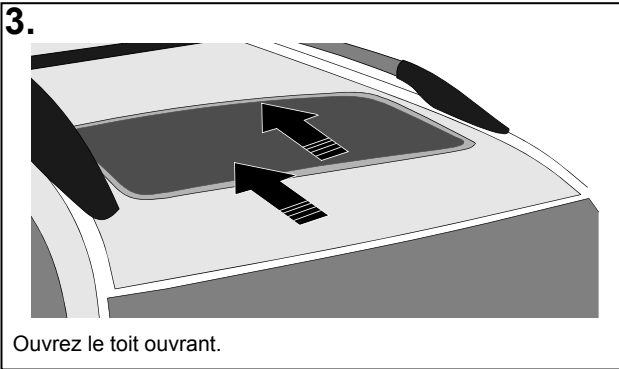
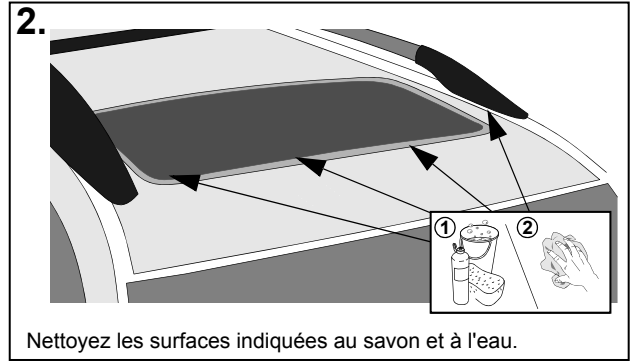
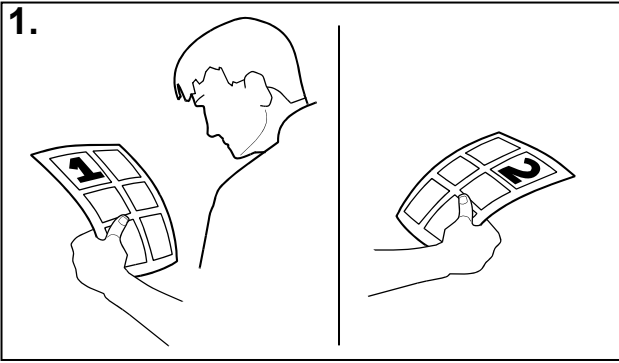

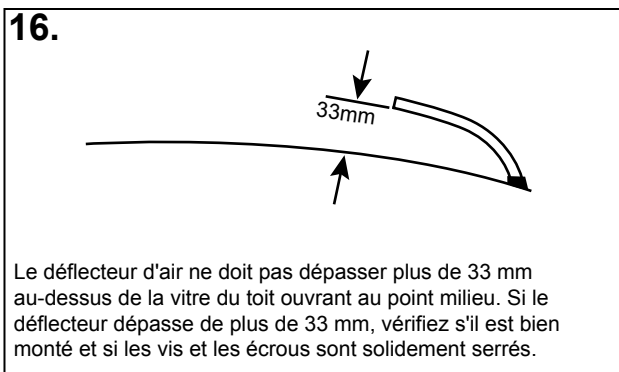
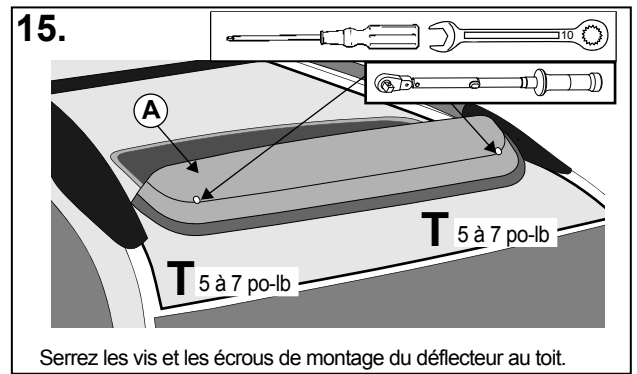
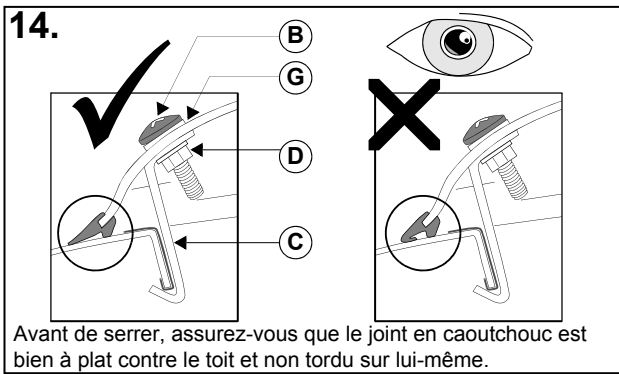
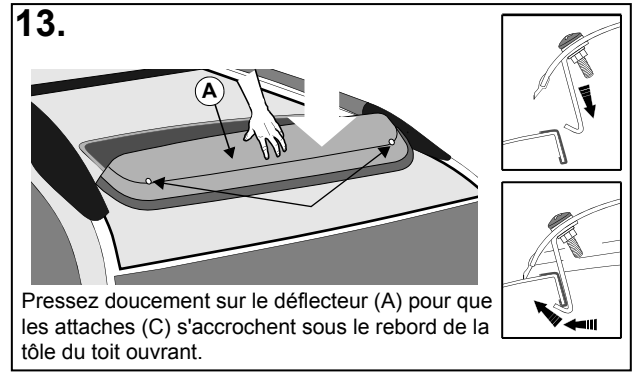
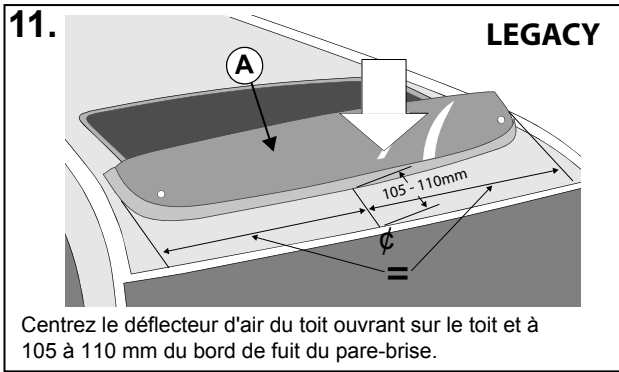
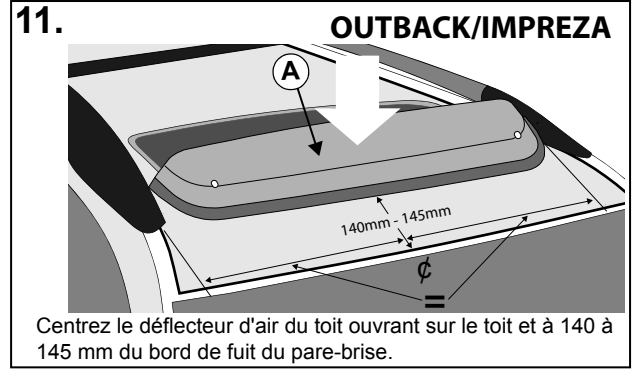
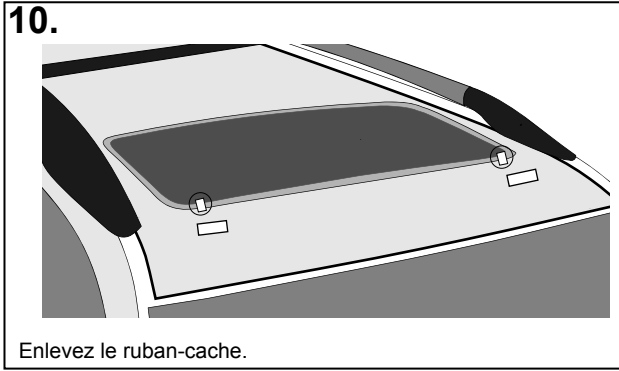

!
N'UTILISEZ PAS de nettoyant à solvant sur le déflecteur d'air du toit ouvrant. UTILISEZ uniquement du savon et de l'eau pour nettoyer le déflecteur d'air.

