





INSTALLATION INSTRUCTIONS

PART NUMBER: F541SFL000

DESCRIPTION: MOONROOF AIR DEFLECTOR

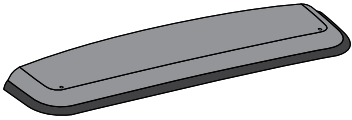
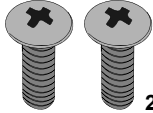
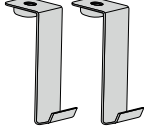
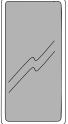
VEHICLE DESCRIPTION: SUBARU CROSSTREK

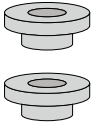
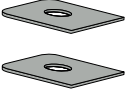
<p>A</p>  <p>1x</p>	<p>B</p>  <p>2x</p>	<p>C</p>  <p>2x</p>	<p>D</p>  <p>2x</p>
<p>E</p>  <p>1x</p>	<p>F</p>  <p>2x</p>	<p>G</p>  <p>2x</p>	

Tools Required

Phillips head screwdriver

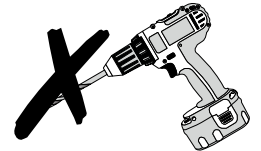
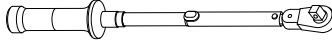

NO POWER TOOLS

Meaning of Characters:



:Remove

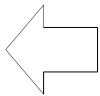

:Install



:Disconnect

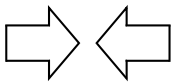

:Connect

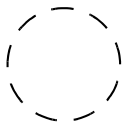

:Location of Clips or Screws

T

:Tightening Torque



:Loosen

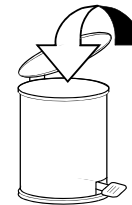

:Discard

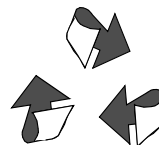

:Re - use

IMPORTANT NOTES

- DO NOT USE SOLVENT BASED CLEANERS ON MOONROOF AIR DEFLECTOR.
- DO NOT USE LOCTITE ON DEFLECTOR ATTACHING SCREWS.
- USE SOAP AND WATER ONLY TO CLEAN MOONROOF AIR DEFLECTOR.

The moonroof air deflector is designed to reduce wind noise when the moonroof is in the opened position. However, in some cases wind noise may be slightly louder with the moonroof in the tilt or closed position.

1.

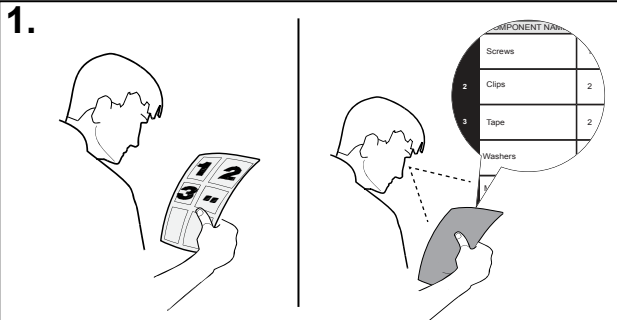

COMPONENT NAME	
Screws	2
Clips	2
Tape	2
Washers	2

Read all steps before commencing & check parts list carefully.

2.

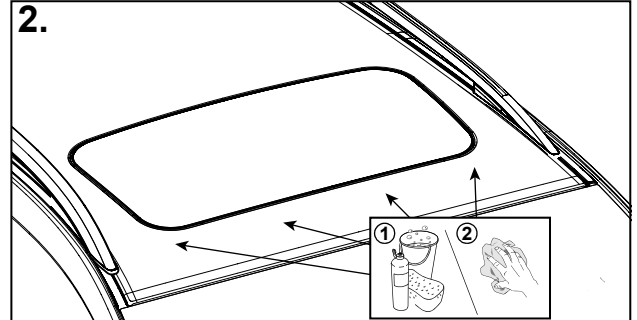

Clean the roof with soap and water. Allow to dry.

3.

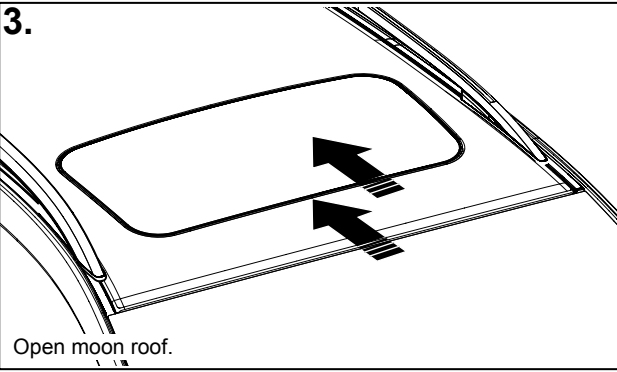

Open moon roof.

4.

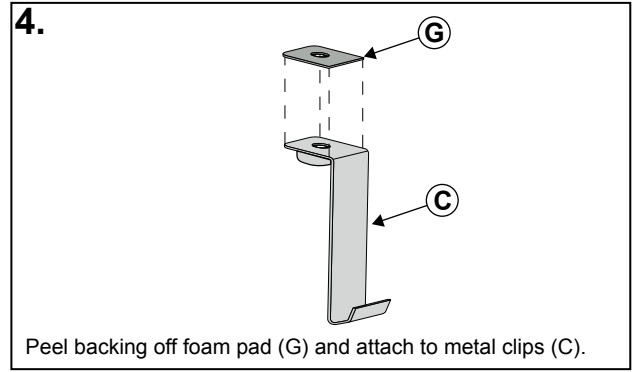

Peel backing off foam pad (G) and attach to metal clips (C).

5.

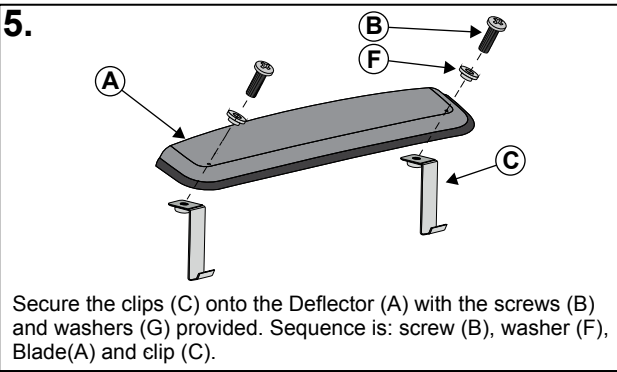

Secure the clips (C) onto the Deflector (A) with the screws (B) and washers (G) provided. Sequence is: screw (B), washer (F), Blade(A) and clip (C).

6.

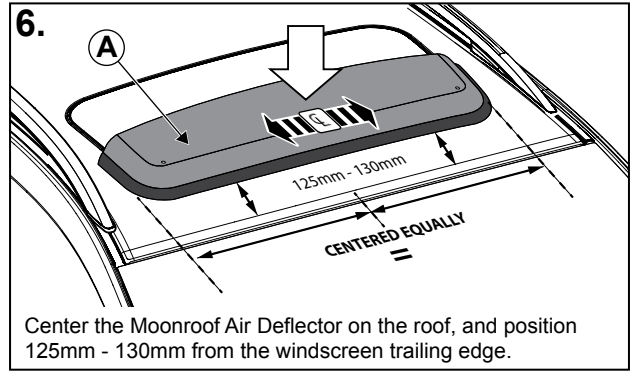

Center the Moonroof Air Deflector on the roof, and position 125mm - 130mm from the windscreen trailing edge.

7.

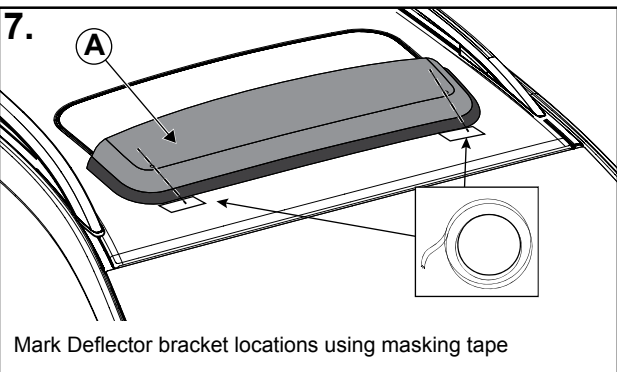

Mark Deflector bracket locations using masking tape

8.

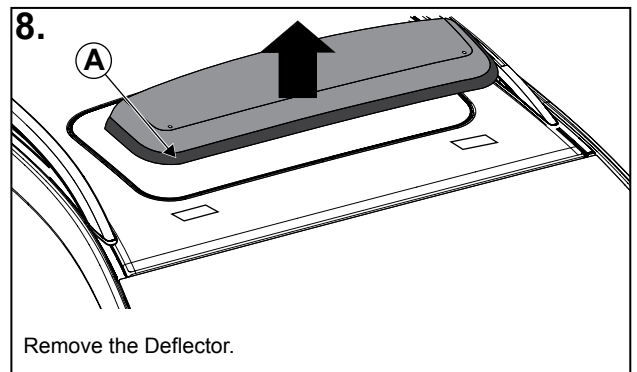

Remove the Deflector.

9.

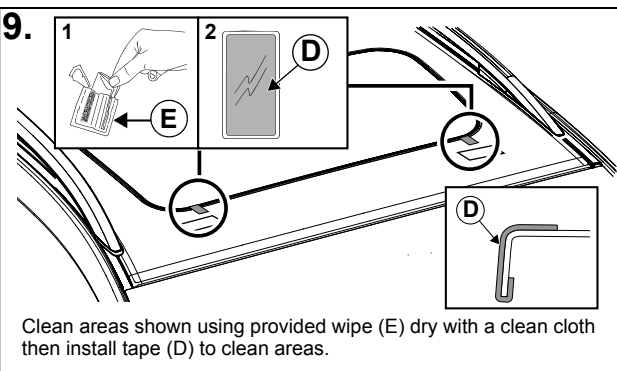

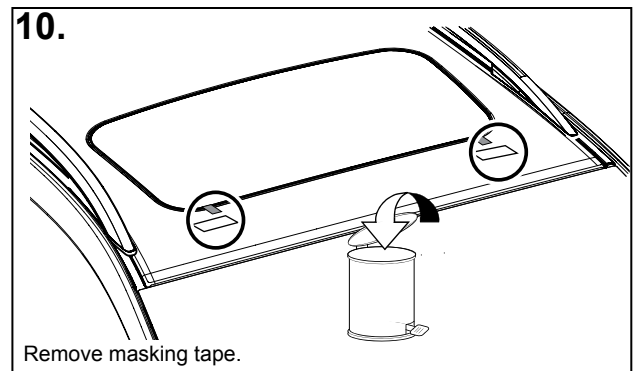

Clean areas shown using provided wipe (E) dry with a clean cloth then install tape (D) to clean areas.

10.

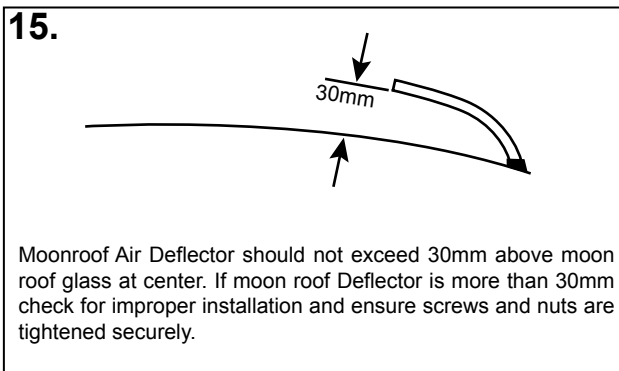
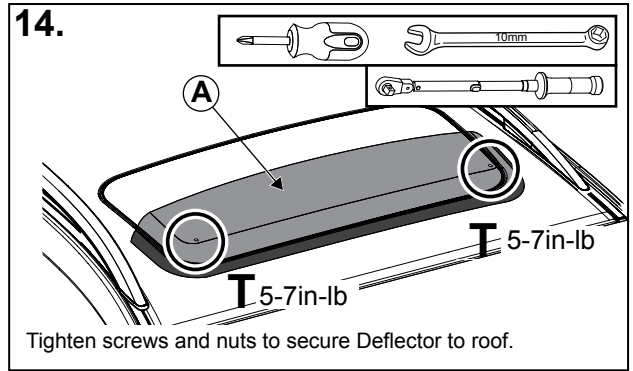
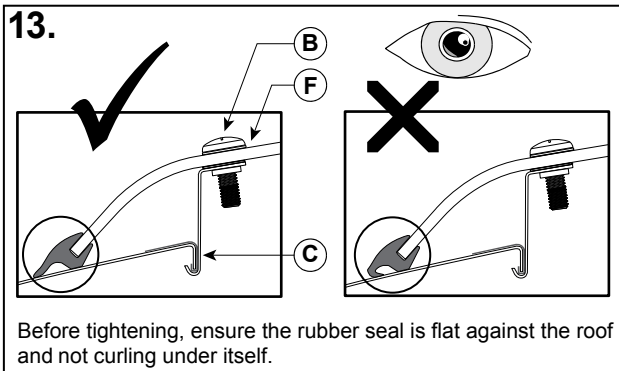
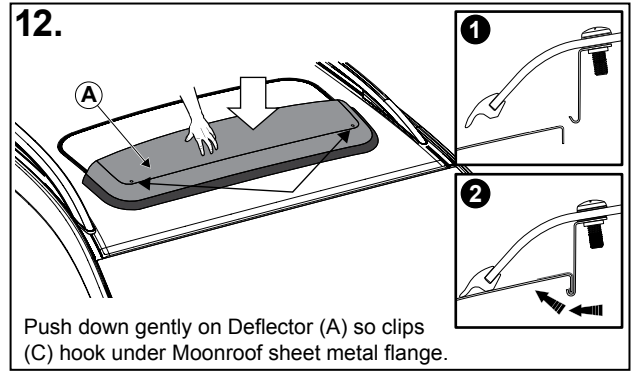
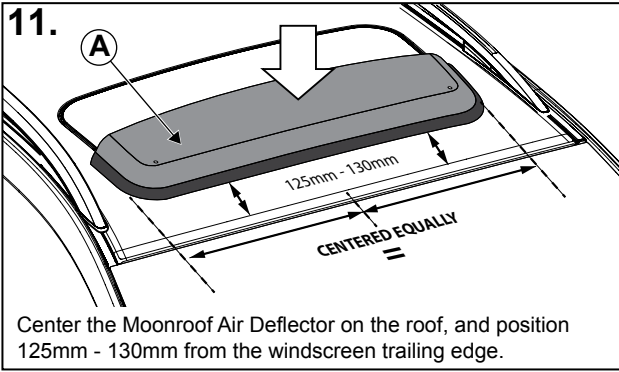

Remove masking tape.



DO NOT USE solvent based cleaners on Moonroof Air Deflector.
USE soap and water only to clean Moonroof Air Deflector.

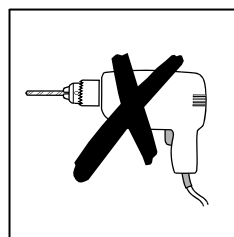







**INSTRUCTIONS
D'INSTALLATION**

NUMÉRO DE PIÈCE : F541SFL000

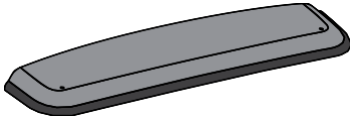
DESCRIPTION : DÉFLECTEUR D'AIR DE TOIT OUVRANT

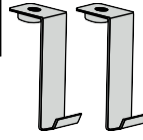
DESCRIPTION DU VÉHICULE : SUBARU CROSSTREK

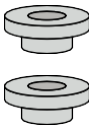
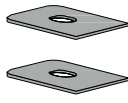
<p>A</p>  <p>1x</p>	<p>B</p>  <p>2x</p>	<p>C</p>  <p>2x</p>	<p>D</p>  <p>2x</p>
<p>E</p>  <p>1x</p>	<p>F</p>  <p>2x</p>	<p>G</p>  <p>2x</p>	

Outils requis

Tournevis Phillips

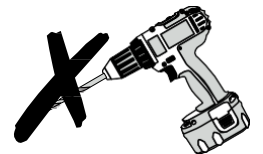
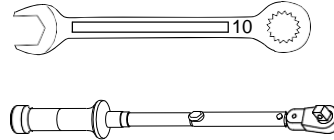

AUCUN OUTIL ÉLECTRIQUE

Signification des symboles :

 : Enlever

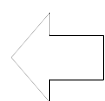
 : Poser

 : Déconnecter

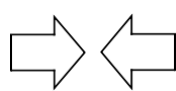
 : Connecter

 : Emplacement des attaches ou vis

T : Couple de serrage

 : Desserrer

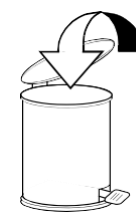
 : Jeter

 : Réutiliser

REMARQUES IMPORTANTES

- N'UTILISEZ PAS DE NETTOYANT À SOLVANT SUR LE DÉFLECTEUR D'AIR DU TOIT OUVRANT.
- N'UTILISEZ PAS DE FREIN FILETS (LOCTITE) SUR LES VIS DU DÉFLECTEUR D'AIR.
- UTILISEZ UNIQUEMENT DU SAVON ET DE L'EAU POUR NETTOYER LE DÉFLECTEUR D'AIR.

Le déflecteur d'air est conçu pour réduire le bruit de vent quand le toit ouvrant est en position ouverte. Toutefois, dans certains cas, le bruit peut être un peu plus fort si le toit est ouvert en inclinaison ou s'il est fermé.

1.

Lisez toutes les étapes avant de commencer et vérifiez attentivement la liste de pièces.

2.

Nettoyez le toit au savon et à l'eau. Laissez-le sécher.

3.

Ouvrez le toit ouvrant.

4.

Décolliez l'endos du coussinet en caoutchouc (G) et apposez ce dernier sur les attaches métalliques (C).

5.

Fixez les attaches (C) sur le déflecteur (A) avec les vis (B) et les rondelles (G) fournies. Voici la séquence : vis (B), rondelle (F), lame (A) et attache (C).

6.

Centrez le déflecteur d'air du toit ouvrant sur le toit et à 125 à 130 mm du bord arrière du pare-brise.

7.

Marquez l'emplacement des supports du déflecteur au moyen de ruban-cache.

8.

Enlevez le déflecteur.

9.

Nettoyez les surfaces indiquées avec la lingette fournie (E), séchez avec un linge propre puis collez le ruban (D) sur les zones propres.

10.

Retirez le ruban-cache

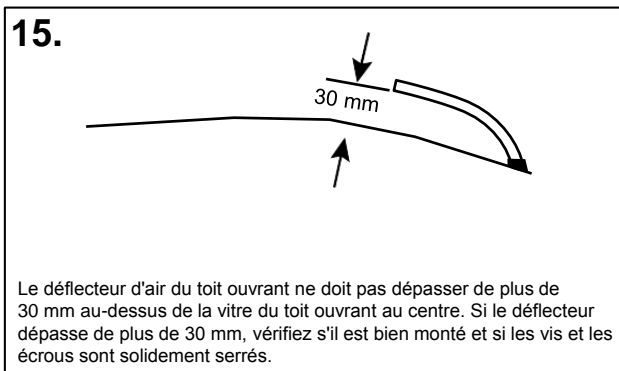
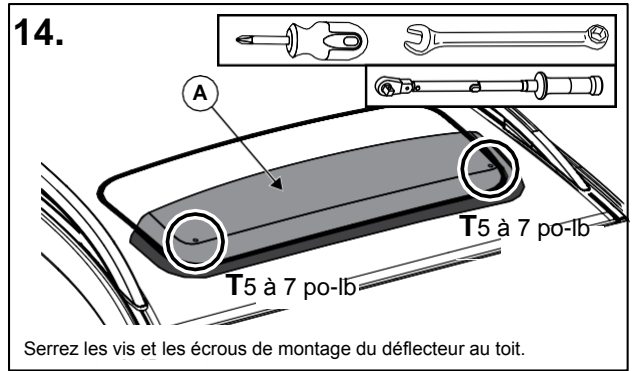
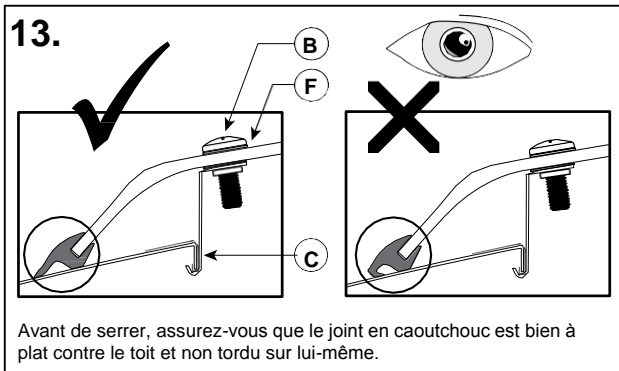
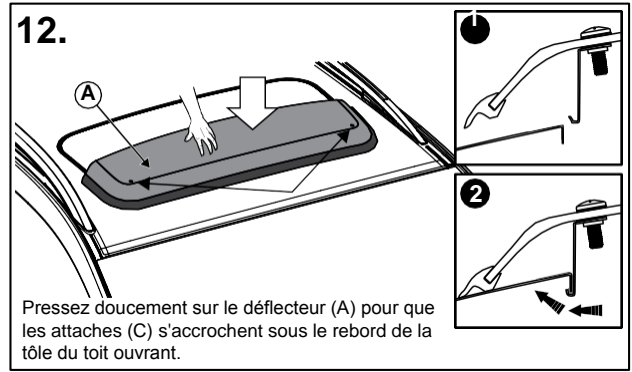
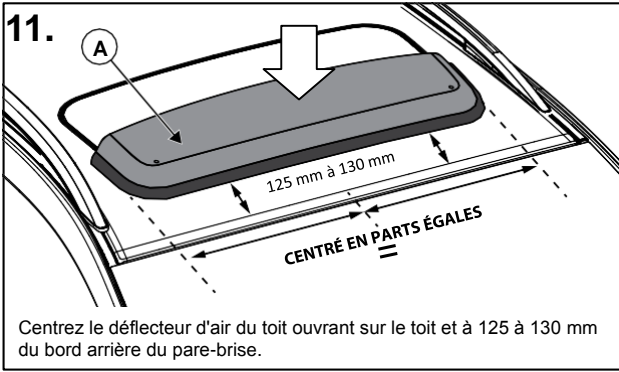

N'UTILISEZ PAS de nettoyant à solvant sur le déflecteur d'air du toit ouvrant.
UTILISEZ uniquement du savon et de l'eau pour nettoyer le déflecteur d'air de toit ouvrant.

