



SUBARU

PART NUMBER: F551SAL701

INSTALLATION INSTRUCTIONS

DESCRIPTION: COMPARTMENT SEPARATOR

A

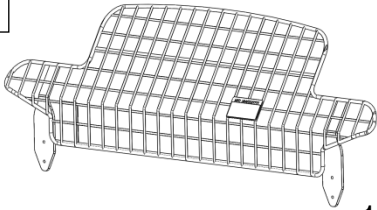

1X

B

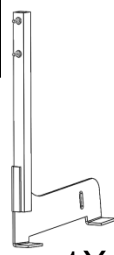

1X

C



1X

D

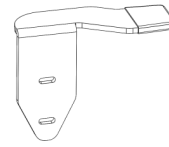

1X

E

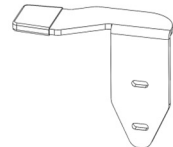

1X

F

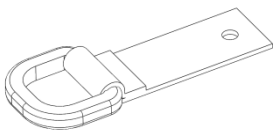

2X

G

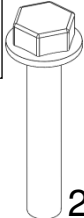

2X

H



2X

I



4X

J

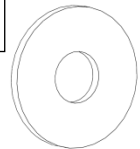

4X

TOOLS REQUIRED

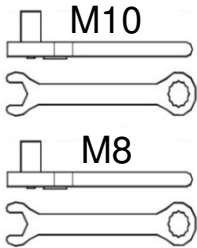

TORQUE WRENCH



FINAL ASSEMBLY

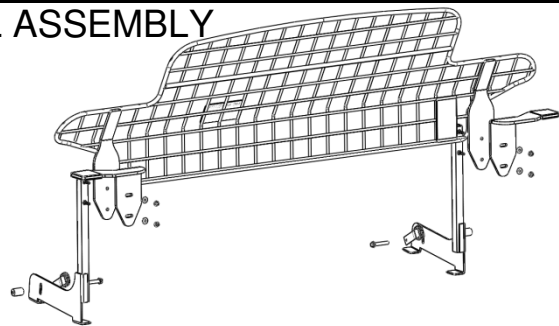

Meaning of Characters:

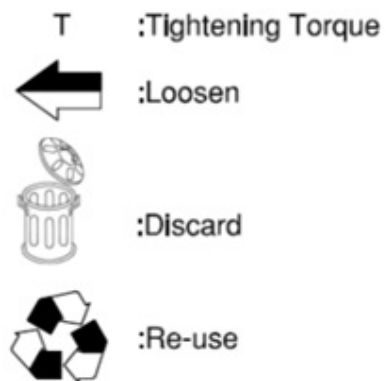
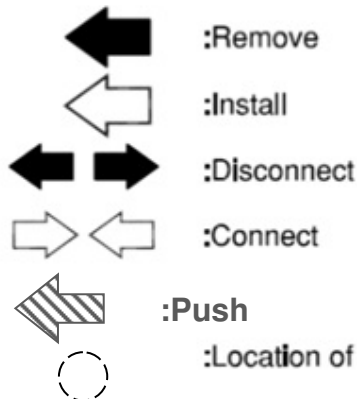

This product has been designed to allow for proper function of various vehicle safety components. The separator does not interfere with the shoulder strap belt for the rear center seat. In addition, the separator is bent toward the rear of the vehicle to allow for proper side curtain air bag clearances in the event of air bag deployment.

Note: This compartment separator is not suitable for containment of a pet. The compartment separator is designed to prevent average cargo larger than 5" x 9" stored in the cargo area from entering into the passenger compartment area. Items smaller than 5" x 9" may be able to pass through the openings on the side of the compartment separator that are required to provide clearance for the side curtain air bag.

ISSUE
02



DATE
10/19/2017

SUBARU OF AMERICA

PAGE
1/2

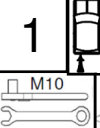

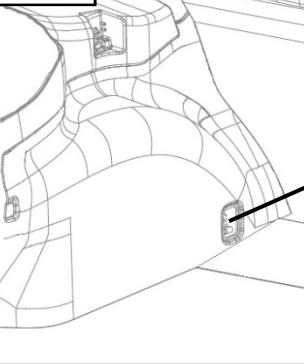
1  OPEN THE COVER TO THE CARGO HOOK ASSEMBLY, REMOVE BOLT AND REMOVE COMPLETE CARGO HOOK ASSEMBLY. REPEAT ON OPPOSITE SIDE.



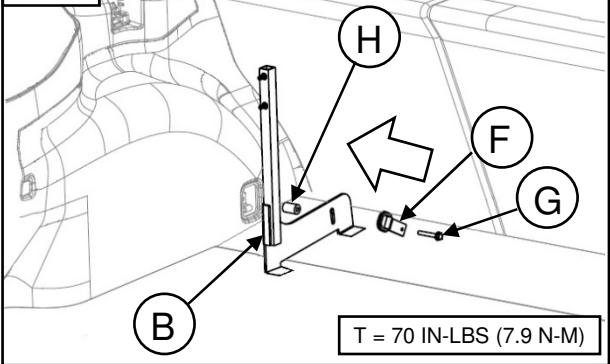

RETAIN FOR FUTURE USE

2  INSTALL BOTTOM LEFT BRACKET, TORQUE TO 70 IN-LBS. REPEAT ON OPPOSITE SIDE USING BRACKET (C).



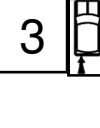

T = 70 IN-LBS (7.9 N-M)

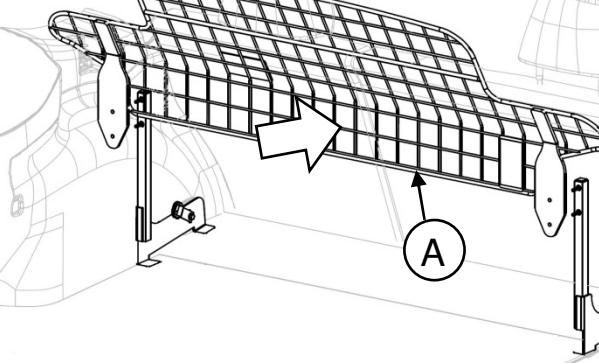
3  LIFT MESH (A) ONTO STUDS AND REPEAT ON OPPOSITE SIDE.

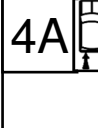

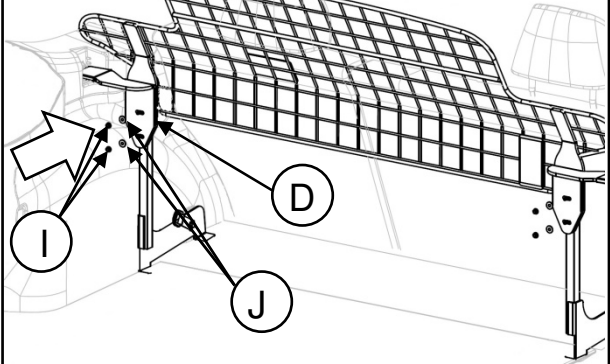
4A  INSTALL SIDE BRACKET (D) ONTO STUDS AND INTO CARGO COVER POCKET, WITH TWO NUTS (I) AND TWO WASHERS (J). REPEAT ON OPPOSITE SIDE USING BRACKET (E).



4B  SIDE BRACKET TO BE POSITIONED UNDER THE LATCH. REPEAT ON OPPOSITE SIDE.

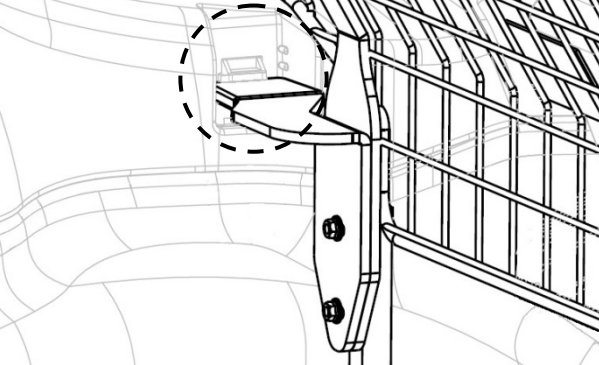

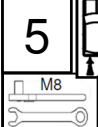
5  PUSH OUT ON SIDE BRACKET TO ENSURE A TIGHT FIT IN THE CARGO COVER POCKET, TORQUE TO 55 IN-LBS. REPEAT ON OPPOSITE SIDE. TORQUE IN ORDER SHOWN.

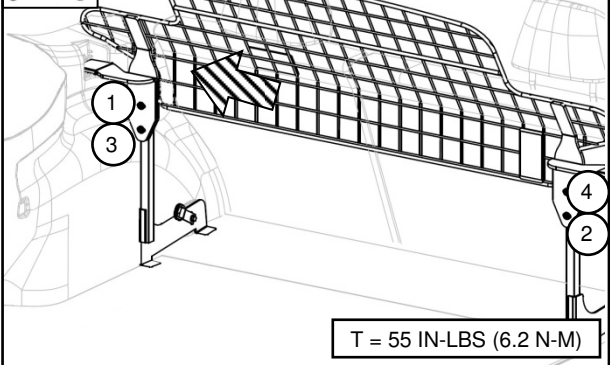

T = 55 IN-LBS (6.2 N-M)