



SUBARU

Part number: H501SFN000
Numéro de pièce:

Vehicle: Crosstrek/ Impreza
Véhicule:

Installation instructions
Instructions d'installaition

Description: Auto dimming mirror
Description: Tetroviseur antiéblouissement

Kit contents

Contenu de la trousse

A

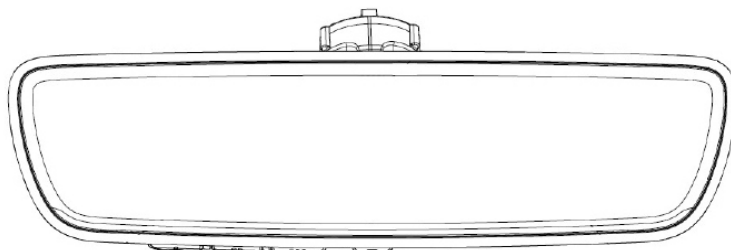

Auto dimming mirror
Tetroviseur antiéblouissement

B



Wire harness
Faisceau de câblage

C

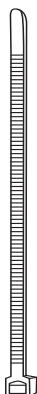

Wire Tie
Attache autobloquante

D

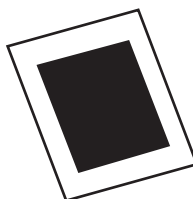

Foam Tape
Ruban mousse

Tools required
Outils requis

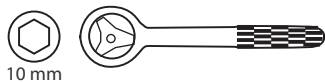

10 mm



Panel removal tool
Outil de dépose du panneau



PART NUMBER
H501SFN000

ISSUE
A

DATE
6/1/2022

SUBARU OF AMERICA

PAGE
1/6

1

10 mm

Disconnect battery cable from the negative battery stud.
Débranchez le câble de la batterie de la borne négative de la batterie.

2

Remove cover with panel removal tool
Retirez le couvercle à l'aide de l'outil de dépose de panneau

3

Remove 2 screws
Enlevez 2 vis

4

Pull assembly down to disengage
Tirez l'ensemble vers le bas pour le désengager

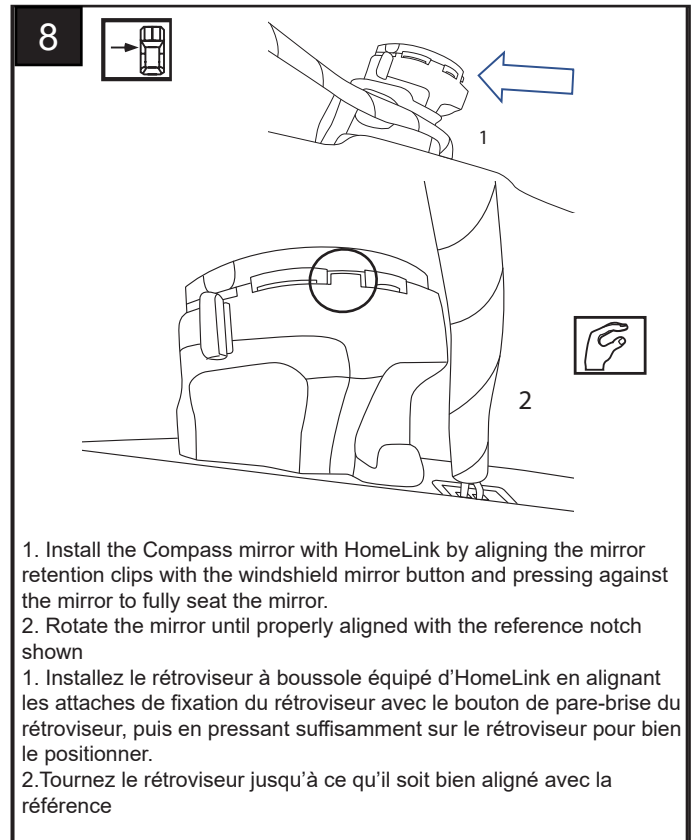
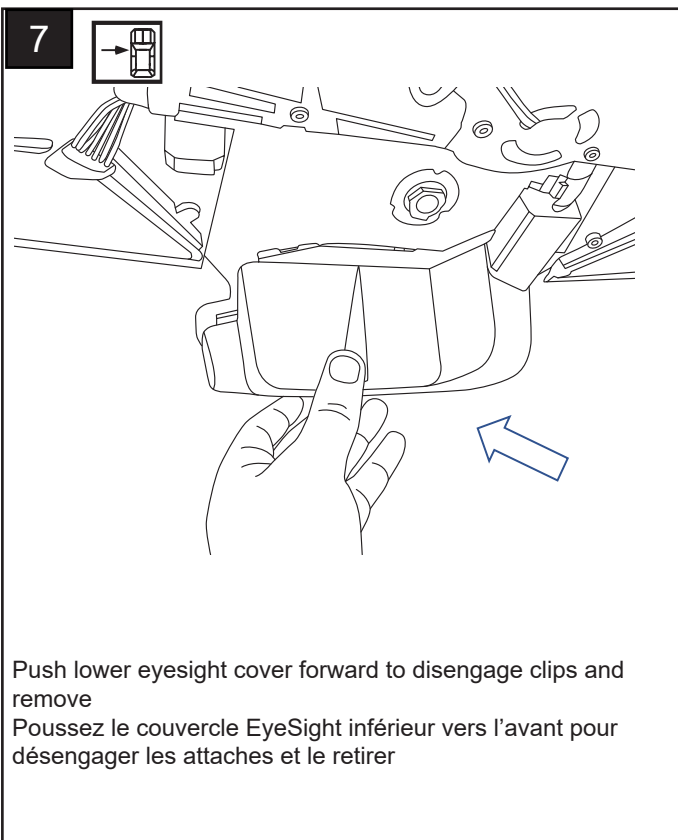
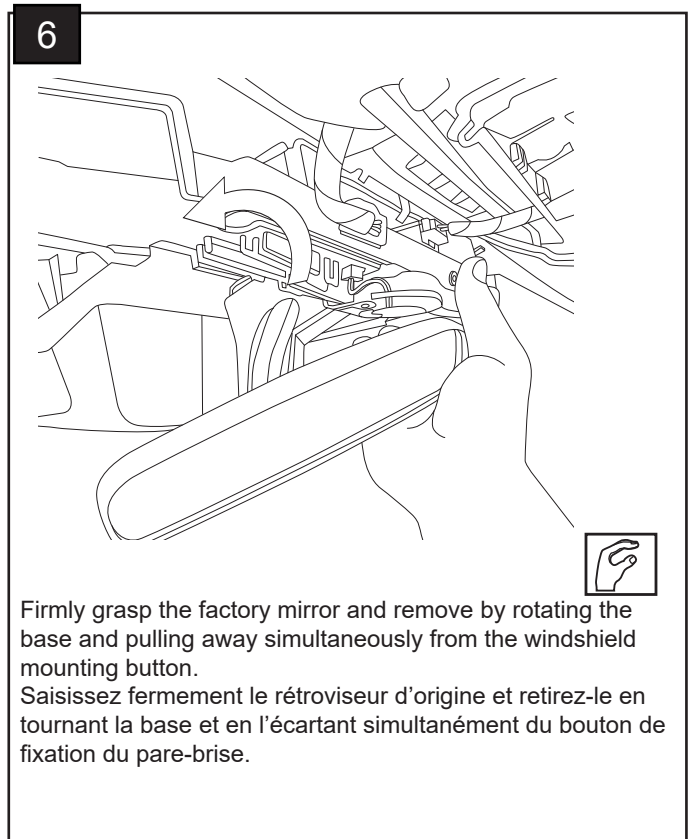
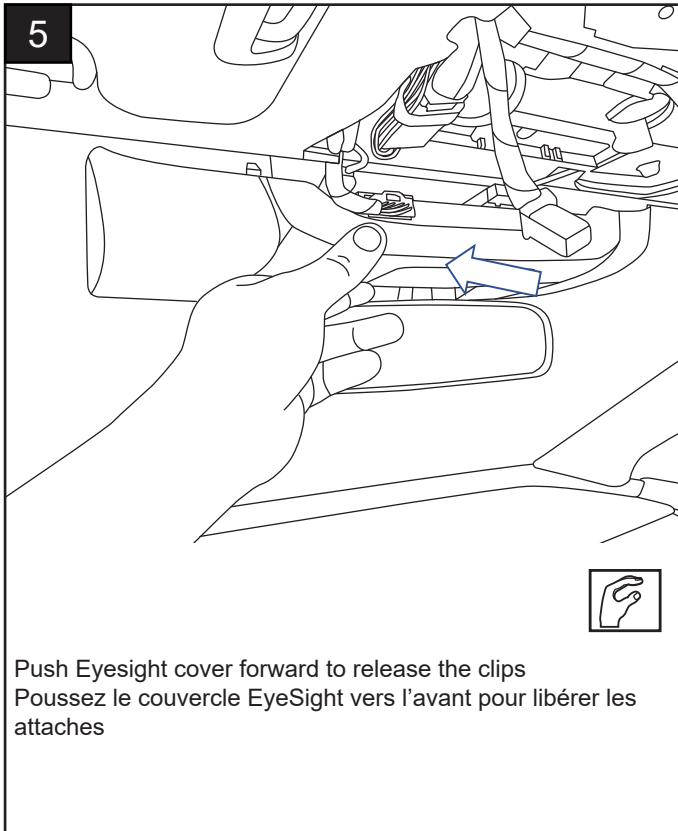

9

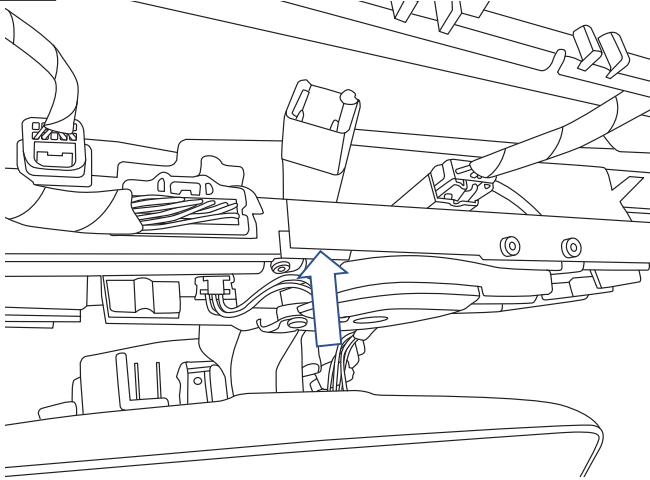

Route mirror connector over eyesight module and slide onto connector tab
Acheminez le connecteur du rétroviseur par-dessus le module EyeSight et glissez-le vers languette du connecteur

10

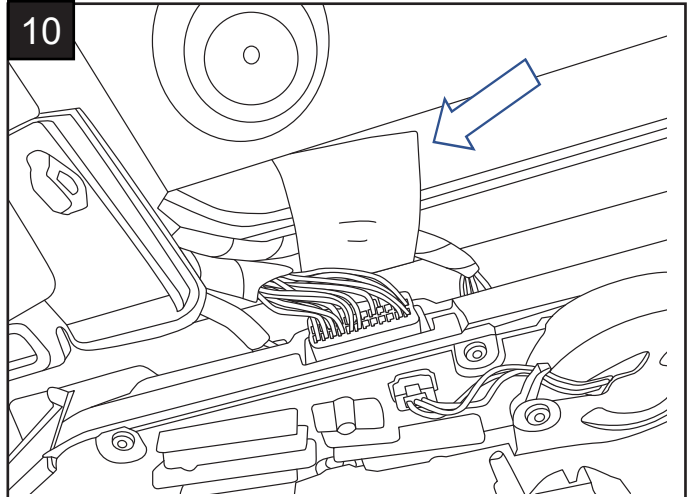

1. Plug jumper harness into pre-wire connector and mirror
 2. Collect and tape excess harness to sheet metal using foam tape and zip tie
1. Branchez le faisceau cavalier dans le connecteur de précâblé et dans le rétroviseur et
 2. Ramassez l'excédent de faisceau puis collez-le sur la tôle à l'aide de ruban mousse et attachez-le

11

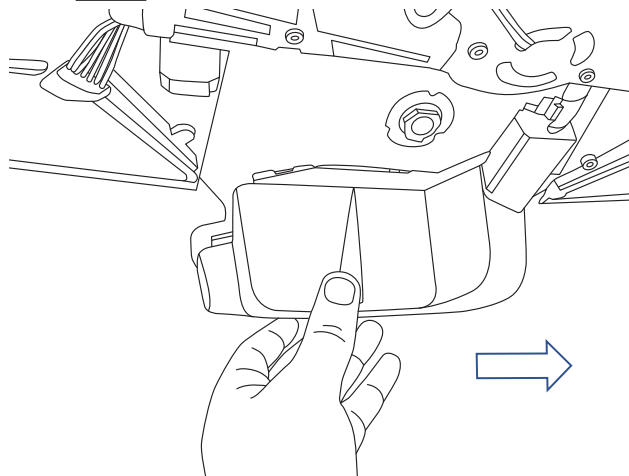

Re-install lower eyesight cover by setting up and pulling rearward
Réinstallez le couvercle inférieur EyeSight en le soulevant et en le tirant vers l'arrière

12

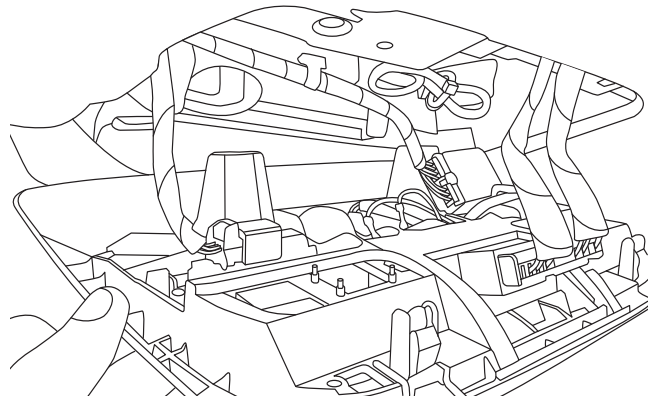

Plug in connectors
Branchez les connecteurs

PART NUMBER
H501SFN000

ISSUE
A

DATE
6/1/2022

SUBARU OF AMERICA

PAGE
4/6

13

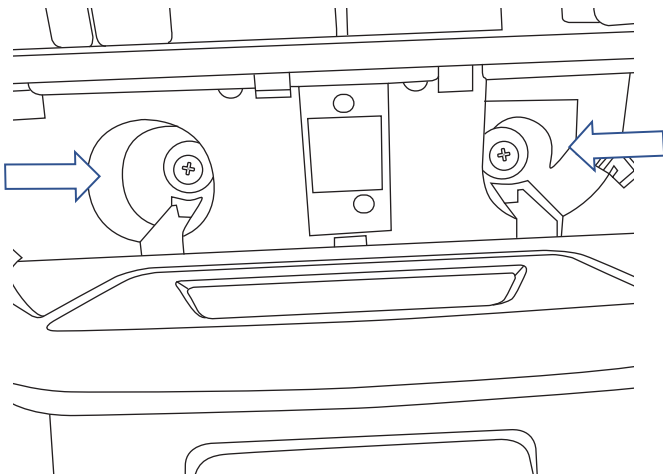

Re-install 8mm bolts
Réinstallez les boulons de 8 mm

14

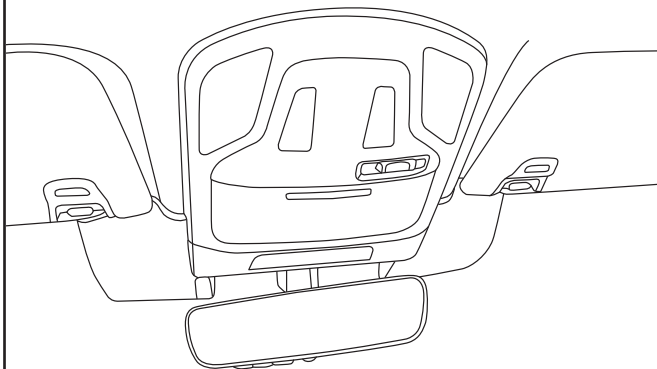

View of reinstalled components
Vue des composants réinstallés

15

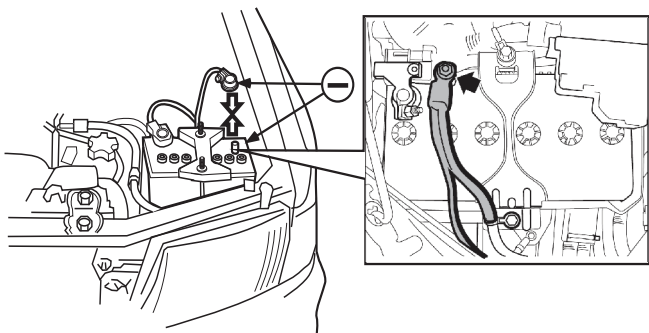

10 mm

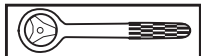

Reconnect battery. If equipped reconnect eyelet cable. Tighten bolt to 66 in-lbs.

Rebranchez la batterie. Si elle en est équipée, rebranchez le câble de l'œillet. Serrez les boulons à 66 po-lb.

PART NUMBER
H501SFN000

ISSUE
A

DATE
6/1/2022

SUBARU OF AMERICA

PAGE
5/6

16

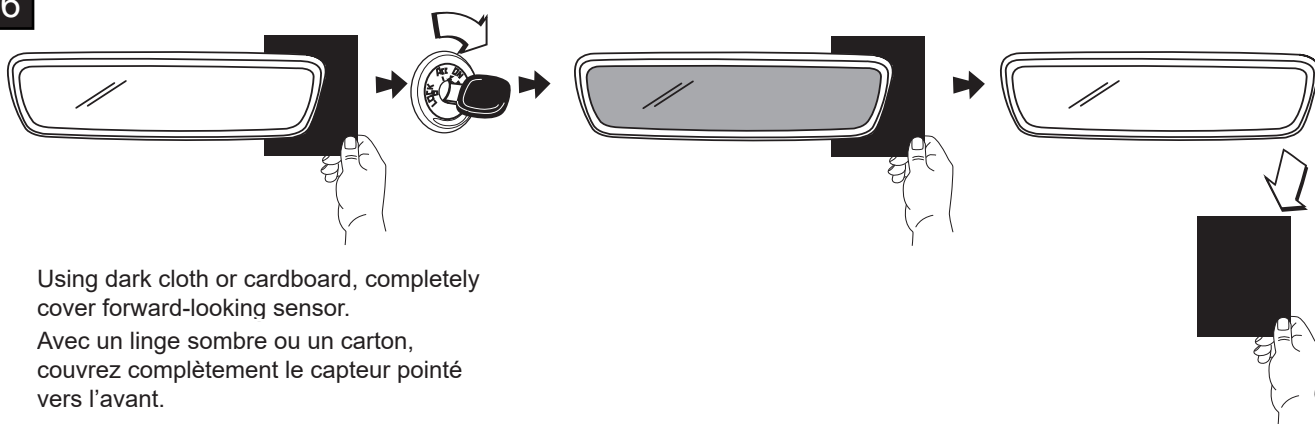

Using dark cloth or cardboard, completely cover forward-looking sensor.

Avec un linge sombre ou un carton, couvrez complètement le capteur pointé vers l'avant.

17

To calibrate compass reference mirror user guide.
Pour étalonner la boussole, reportez-vous au manuel du rétroviseur.