



REAR STEP GUARD

(REAR DOOR SILL STEP GUARD)

Installation Manual

Genuine Part Number: J1010AN400

Applicable Model: OUTBACK (2020MY ~)

Request

Please make sure to read this manual before installing the step guard to ensure proper installation. If you do not follow the precautions, then the car may be damaged or the product may peel off or tear, resulting in a serious accident.

⚠ Precautions for installation

1. Carry out the installation work in a large open area free from obstructions to ensure safety.
2. Turn OFF the engine and securely apply the parking brake before carrying out the work.
3. Pooling of cleaning agent may deteriorate car parts. Soak a soft cloth with a cleaning agent and carefully wipe the areas that need cleaning so as to prevent dripping, and then wipe them with a dry cloth.
4. When the air temperature is 15°C or lower, use a hair dryer to warm up (to approximately 30 to 50°C) the double-sided tape on the product and the car surface to which the product is to be attached. Do not use an industrial dryer.
5. In order to pressure bond the double-sided tape, apply weight to the product (use the palm of your hand to apply a force of 50 N or higher) .
6. Do not apply a load to the product for 24 hours after the installation.
7. When blowing air on the product after the installation, maintain a distance of at least 300 mm between the exhaust port of the blower and the product.
8. Reattaching the product reduces the adhesive strength of the tape. Carry out the work with care to prevent the need for reattachment work. Do not reuse the product once it has been peeled off.

Components

(Be sure to check the components before starting work)

No.	Part Description	Quantity
①	Step guard RH	1
②	Step guard LH	1

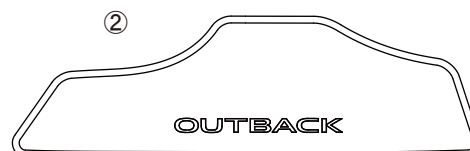
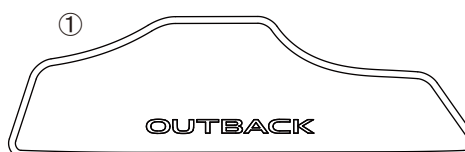

Tools

Soft lint-free cloth / 70% Isopropyl alcohol / Masking tape

Revised contents

△	Details of the work	date
00	Newly created document	2022/7/29

Completion drawing

The completion drawing and installation procedures show how to install the RH (Right hand) side step guard. The LH (Left hand) side installation can be carried out in the same manner as the RH side.

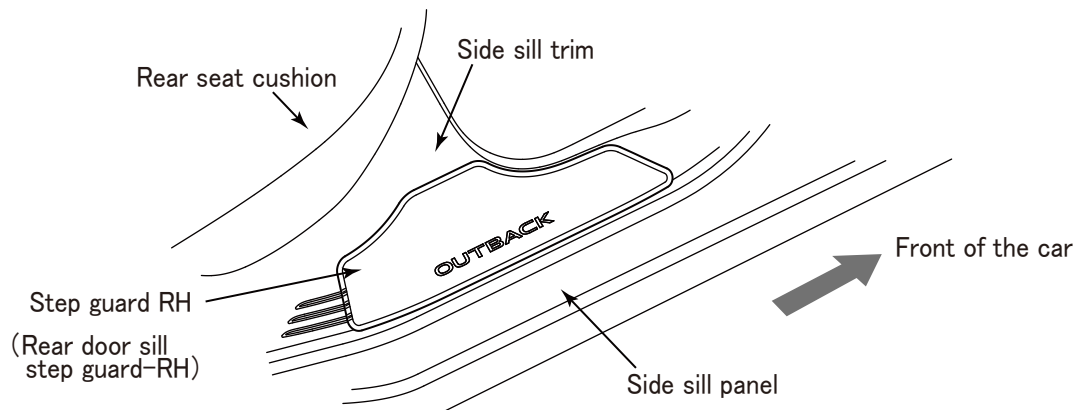

Installation procedures

1. Clean the side sill trim's surface to which the step guard is to be attached, and apply masking tape to position the step guard.

- 1) Use isopropyl alcohol to remove dirt adhering to the entire top surface of the side sill trim, and dry thoroughly.
- 2) Apply masking tape to the two areas separated by 12mm from the outside of the trim pattern as shown in the figure below.

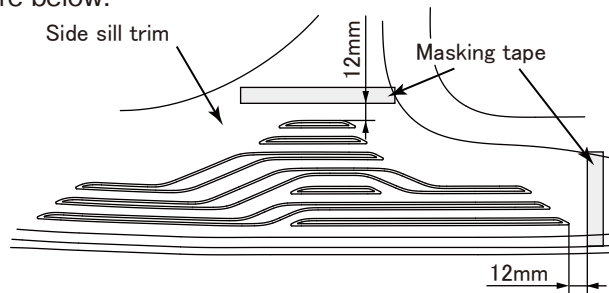

2. Attach the step guard to the side sill trim.

- 1) Refer to image below. Fully remove 8 of the double-side tape release film on the back of the step guard. On the two long pieces of tape (#1 and #2), partially peel and fold back about 70mm of the release film. See caution note on fold back sequence.
- 2) By referring to the figure below, align the top and front ends of the step guard with the two pieces of masking tape described in the previous section, and align the respective three lines located on the rear edge of the step guard and the side sill trim, and then attach the guard to the trim with double-sided tape. Once in the proper position, slowly remove #1 and #2 release film while checking straightness.
- 3) In order to carry out pressure bonding, apply weight to the product (use the palm of your hand to apply a force of 50 N or higher).
- 4) Remove all pieces of masking tape and touch the outer edge of the step guard to confirm that there is no peeling.
- 5) Install the LH side step guard in a similar manner.

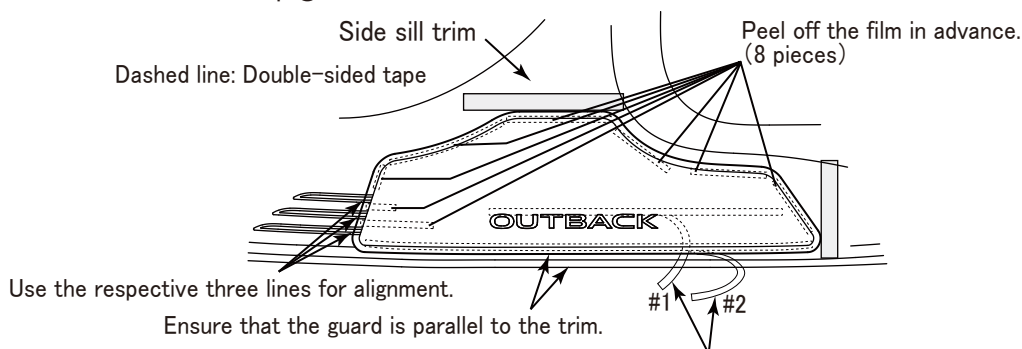

Peel and fold back about 70mm. Tip: Crease the release film to help it stay.
CAUTION: Fold #1 first and then #2 as shown, otherwise #1 may become trapped.
Once the part is properly positioned, remove #1 and #2 slowly while checking straightness.