



SUBARU

INSTALLATION INSTRUCTIONS

PART NUMBER: L101SFN000

DESCRIPTION: CROSSTREK
TRAILER HITCH

**PLEASE READ THIS INSTRUCTIONS CAREFULLY, BEFORE YOU START
INSTALLATION**

SAFETY PRECAUTION: When installing Trailer Hitch, the use of safety glasses is recommended.

WARNING:

1. Always install the accessory following the instructions. Failure to do so may cause damage to the vehicle or the accessory.
2. Please also refer to SUBARU SERVICE MANUAL upon removing and re-assembling vehicle components.
3. Do not drill, cut, weld or otherwise modify the Trailer Hitch.
4. Do not lubricate the bolts and nuts with oil or grease.
5. If Trailer Hitch is removed, a bumper beam **MUST** be reinstalled. Failure to reinstall a bumper beam after removal of the trailer hitch will negatively affect vehicle rear crash performance. Please contact your SUBARU dealer.
6. When a Trailer Hitch is installed, it is not possible to install the rear towing hook.
7. Never exceed the maximum towing capacity and maximum tongue load. It could cause personal injury and/or vehicle damage.
8. When towing, total vehicle weight must not exceed the Gross Vehicle Weight Rating (GVWR). Also the load distribution on each axle must not exceed the Gross Axle Weight Rating (GAWR). The GVWR and GAWR for your vehicle can be found on the "Certification label" which is located on the left side center pillar of the vehicle.
9. For models equipped with RAB, refer to the part which indicated [RAB].
10. Ensure all recyclable discarded vehicle accessory components and packaging are recycled following local recycling regulations.
11. It is always recommended that this accessory is fitted by a qualified SUBARU technician.
12. In the engine bay, disconnect the negative battery terminal.
13. Safely store and protect any removed vehicle components.
14. Ensure all bare metal surfaces are protected using Automotive Bare Metal Primer and touch-up paint.
15. Remove all metal swarf and dust from all vehicle surfaces if surface is used for accessory installation.
16. Tow hitch to be used with Subaru ball mounts L101SFN200 (3500 lb tow rate) and L101SFN250 (1500 lb tow rate). Please see dealer for correct ball mount part # application.

Warranty is granted only when installation is done correctly by your SUBARU dealer.

SUBARU reserves the right to change the design of accessories and/or construction, illustration, and text of this manual at anytime without prior notice.

SPN0004964

PART NUMBER
L101SFN000







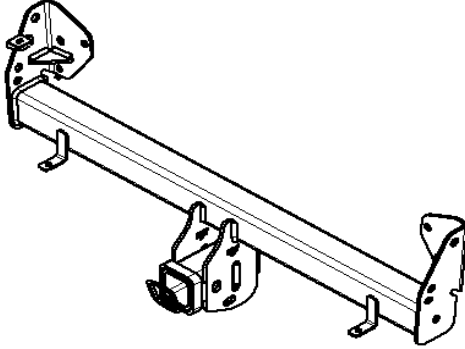
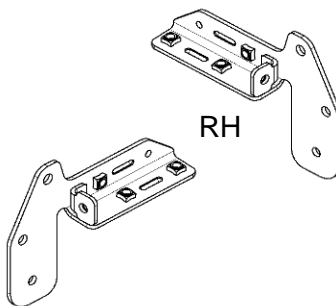
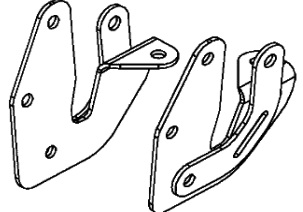
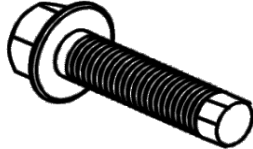
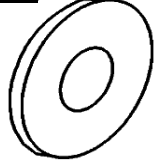

ISSUE
05

DATE
6/7/2023

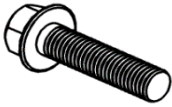

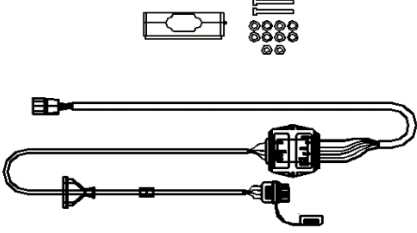

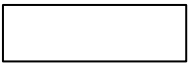





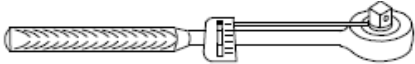

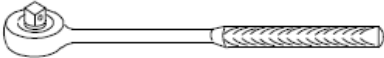
SUBARU OF AMERICA

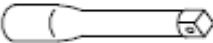
PAGE
1 OF 18

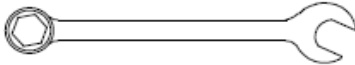
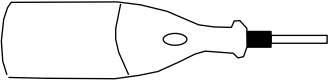
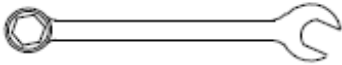
KIT CONTENTS:

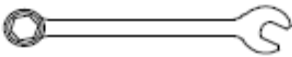
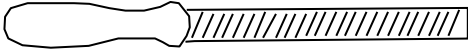
<p>A</p>  <p>x1</p>	<p>B</p>  <p>RH LH</p> <p>x1 set</p>	<p>C</p>  <p>LH RH</p> <p>x1 set</p>		
<p>D</p>  <p>M12 hex flange bolt</p> <p>x14</p>	<p>E</p>  <p>M12 flat washer</p> <p>x6</p>	<p>F</p>  <p>M12 flange nut</p> <p>x4</p>	<p>G</p>  <p>M10 hex flange bolt</p> <p>x2</p>	<p>H</p>  <p>M10 flange nut</p> <p>x2</p>
<p>I</p>  <p>x1</p>	<p>J</p>  <p>x1</p>	<p>K</p>  <p>cable tie - long</p> <p>x2</p>	<p>L</p>  <p>foam tape</p> <p>x2</p>	
<p>M</p>  <p>cable tie mount</p> <p>x1</p>	<p>N</p>  <p>cable tie - 6"</p> <p>x2</p>			

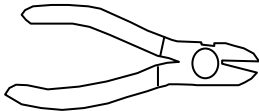
TOOLS REQUIRED:

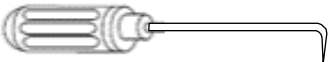
<p>1/2" drive torque wrench</p> 	<p>10 mm socket</p> 
<p>1/2" drive ratchet</p> 	<p>7mm socket</p> 
<p>Flat head screwdriver</p> 	<p>6" socket extension</p> 
<p>Phillips head screwdriver</p> 	<p>automotive paint / primer & brush</p> 
<p>17mm open end wrench</p> 	<p>cutting tool</p> 
<p>14mm open end wrench</p> 	<p>reamer</p> 
<p>7mm open end wrench</p> 	<p>file</p> 
<p>17mm deep well socket</p> 	<p>side cutter</p> 
<p>14mm deep well socket</p> 	<p>clip remover</p> 
<p>hook tool</p> 	

1 REMOVE REAR TAIL LIGHTS

- 1 Using a small Phillips screwdriver, remove (2) plastic clips from the inside tail light cover. Then remove the plastic cover.
- 2 Using a small Phillips head screwdriver and ratchet with 10 mm socket, remove (2) screws from the rear tail light assembly on each side

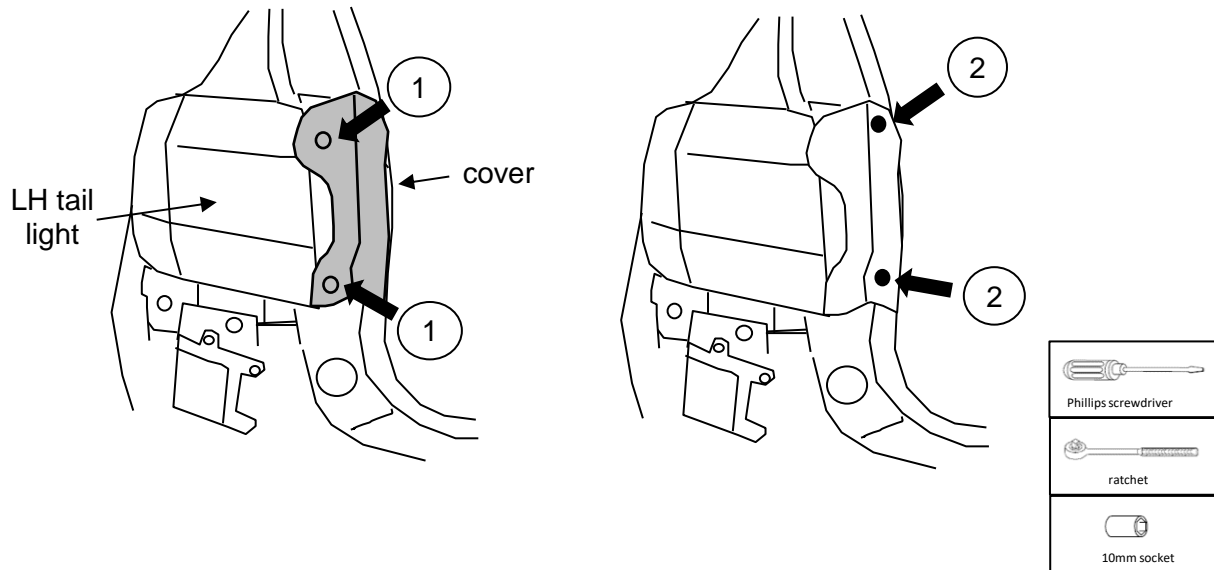

- 3 Carefully slide the tail light assembly rearward in order to remove. Unplug the wire harness connector. Repeat for the other side.

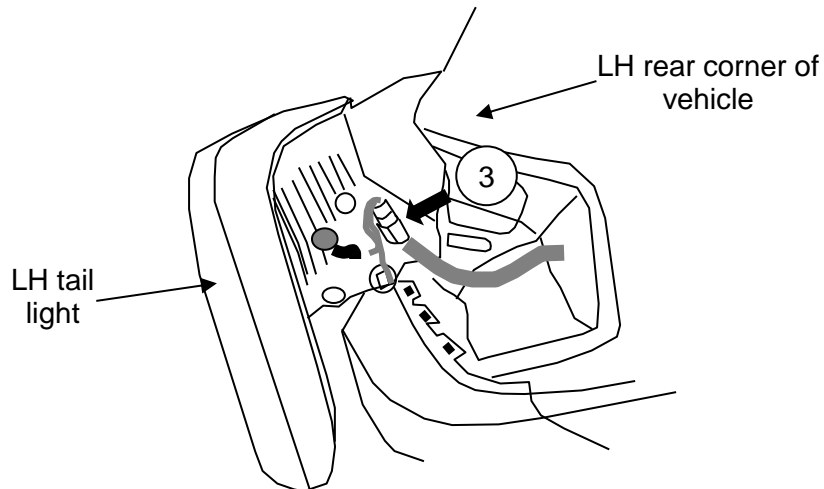

- 4 Carefully set aside the fasteners and tail light assemblies were they will not be damaged

2 REMOVE REAR BUMPER FASCIA

- 1 With a screwdriver, release (1) small push pin fastener per side on the LH/RH fascia wheel well. Use the tip of the screwdriver to push the center of the pin.
- 2 With a small flat head screwdriver, remove (10) large push pin fasteners across the length of the bumper. Save push pins for later use.
- 3 Starting at the LH side wheel well, using both hands, pull one side of the fascia out from the vehicle.
- 4 Continue around the rear LH side. At the rear corner, begin to pull rearward and work across the vehicle from left to right to remove the entire bumper.
- 5 Disconnect the RAB sensor harness.
- 6 Fully release the bumper from the vehicle body.
- 7 Lay fascia aside where it will not be damaged during hitch installation.

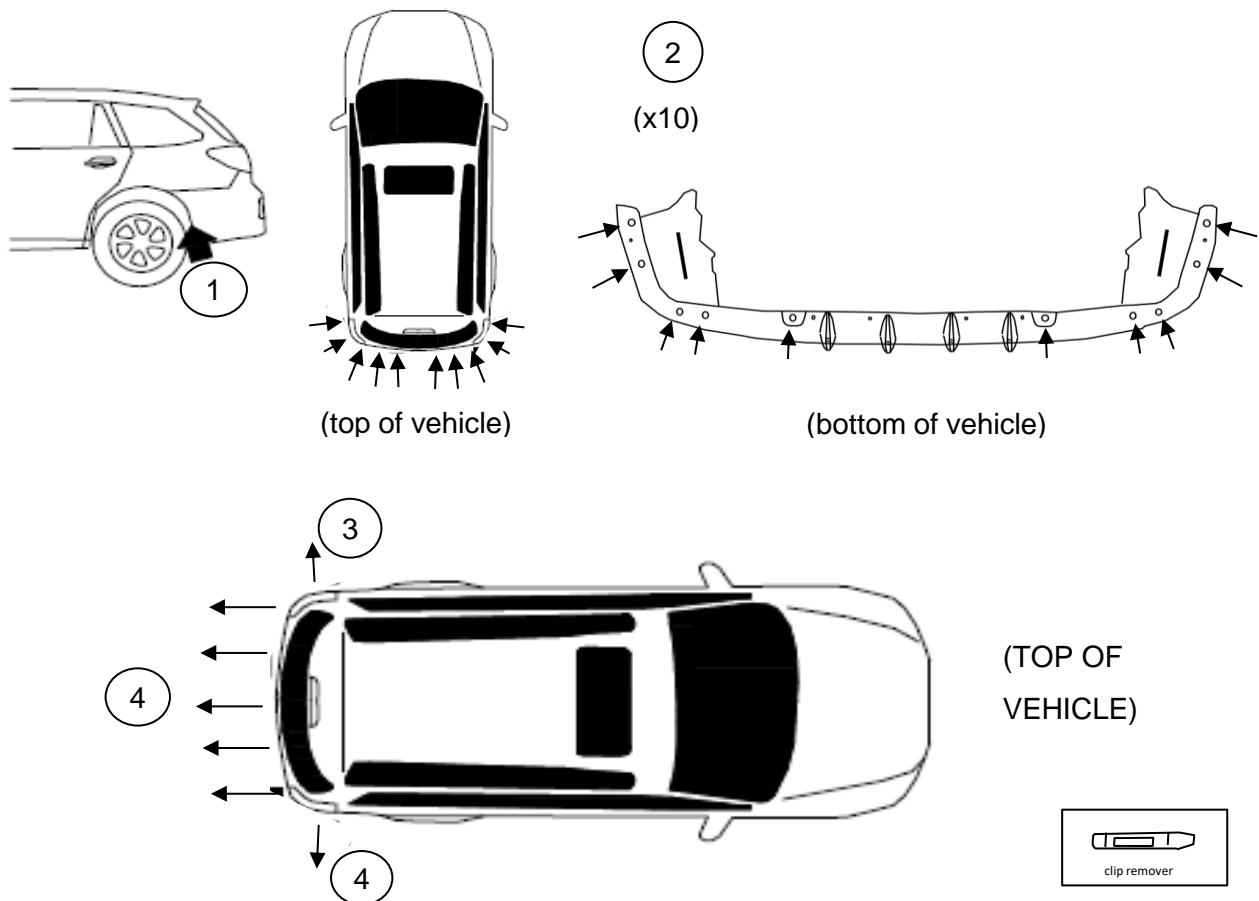

3 REMOVE REAR BUMPER BEAM

- 1 Using 14 mm deep socket, remove (2) bolts and (1) nut from each side of the bumper beam
- 2 Discard (2) nuts and (2) bolts. Retain (2) bolts for later use.

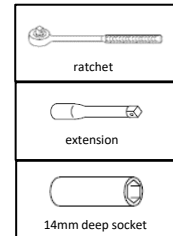
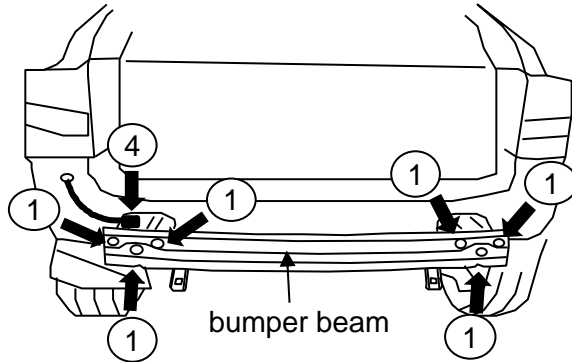

- 3 Carefully release the bumper beam from the vehicle.
- 4 Remove the RAB harness connectors. Unplug the bumper side connector first. Then remove the vehicle side connector plug.
- 5 After removing both connectors, remove the RAB harness clip from the bumper beam by using a hook tool to release the clip while being carefully not to damage it.

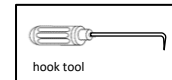
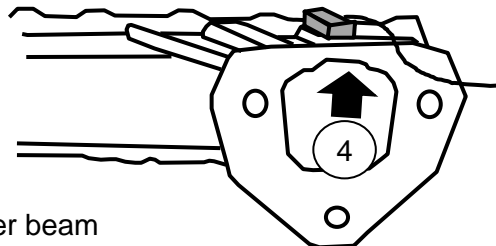

- 6 Remove the bumper beam



If Trailer Hitch is removed, a bumper beam **MUST** be reinstalled. Failure to reinstall a bumper beam after removal of the trailer hitch will negatively affect vehicle rear crash performance. Please contact your SUBARU dealer.

- 7 Remove the bolt and bumper bracket from each side and discard.
- 8 Using touch up paint, paint the bare metal areas on the vehicle where the bumper beam was removed.

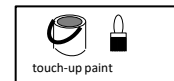
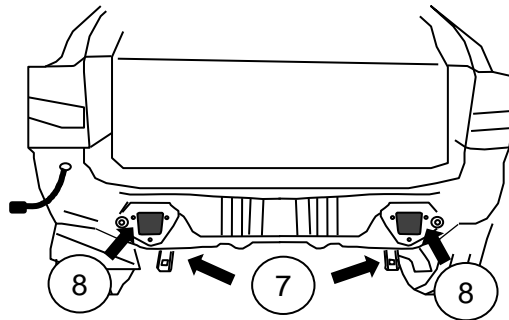

4 INSTALL LH / RH FRAME BRACKET ASSEMBLIES - PART "B"

- 1 Remove (3) rubber grommets per side from the bottom of the side frame.
- 2 Place LH and RH welded bracket subassembly "B" into side frame hole opening.

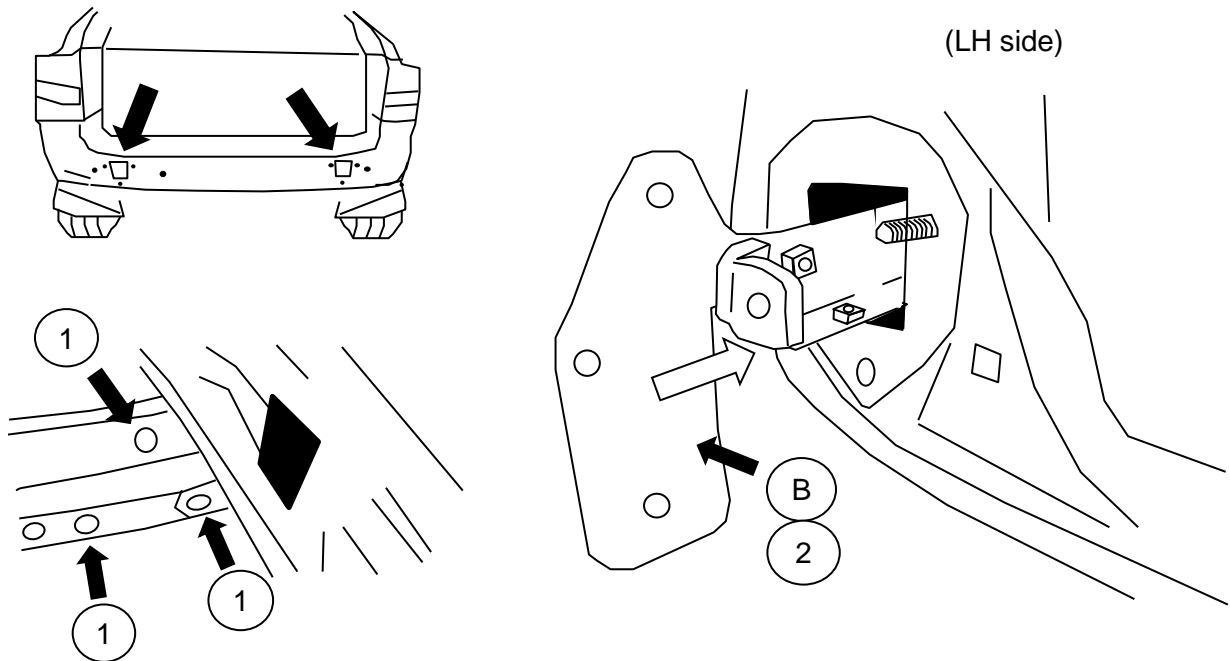

- 3 Align the bracket holes with the holes in the frame rail.
- 4 Loosely install (1) M12 bolt "D" and washer "E" through the bottom of the frame into ONLY the front hole.

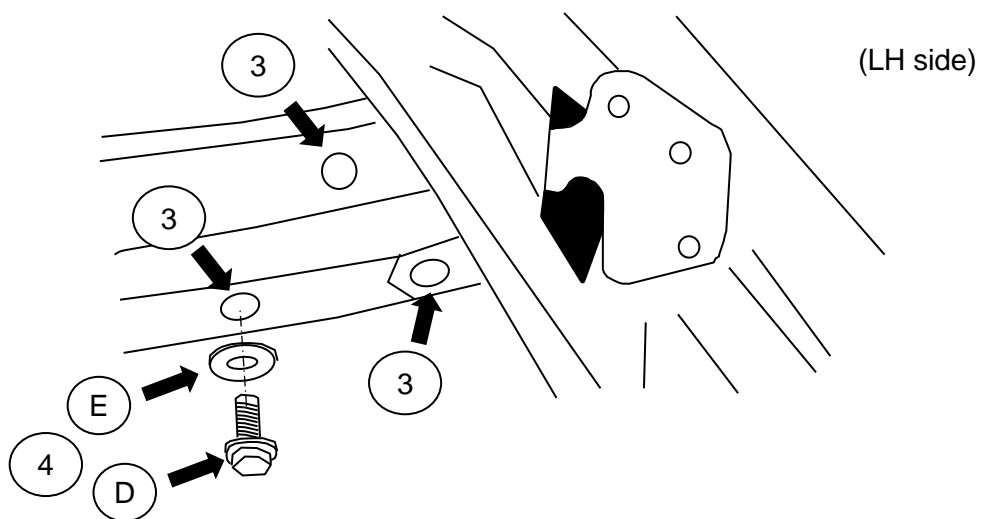

5 INSTALL LH / RH FRAME BRACKET ASSEMBLIES - PART "C"

- ① Install frame bracket subassembly "C" on the outside of frame bracket subassembly "B".
- ② Align the holes the frame holes of part "C" to the (1) bottom and (1) side hole in the frame rail.
- ③ Install (1) M12 bolt "D" and washer "E" into the side hole on each side, through the frame, and into the weld nut of part "B".
- ④ Install (1) M12 bolt "D" and washer "E" into the bottom hole on each side, through the frame, and into the weld nut of part "B".

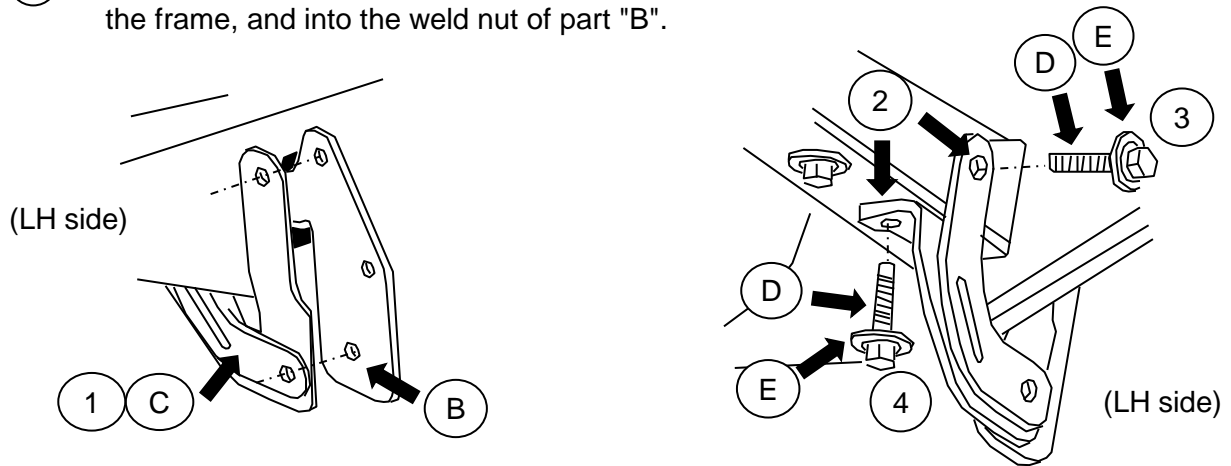

6 INSTALL MAIN HITCH MEMBER - PART "A"

- ① Install the main hitch "A" between the LH and RH frame bracket subassemblies and onto the vehicle rear panel weld bolts.
- ② Loosely install (1) M10 nut "H" on each side onto the vehicle weld bolts.
- ③ Loosely install (1) M10 bolt "G" on each side into the vehicle weld nuts.
- ④ Loosely install (1) M12 bolt "D" on each side into the frame bracket weld nuts.

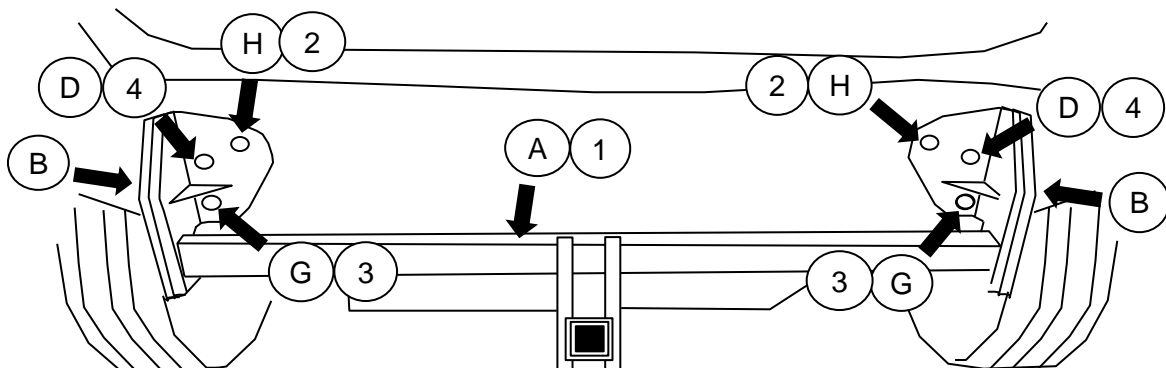

7 ATTACH ALL PARTS TOGETHER.

- ① Install (3) M12 bolts "D" and (2) M12 flange nuts "F" per side through brackets "B", "C", and hitch member "A"

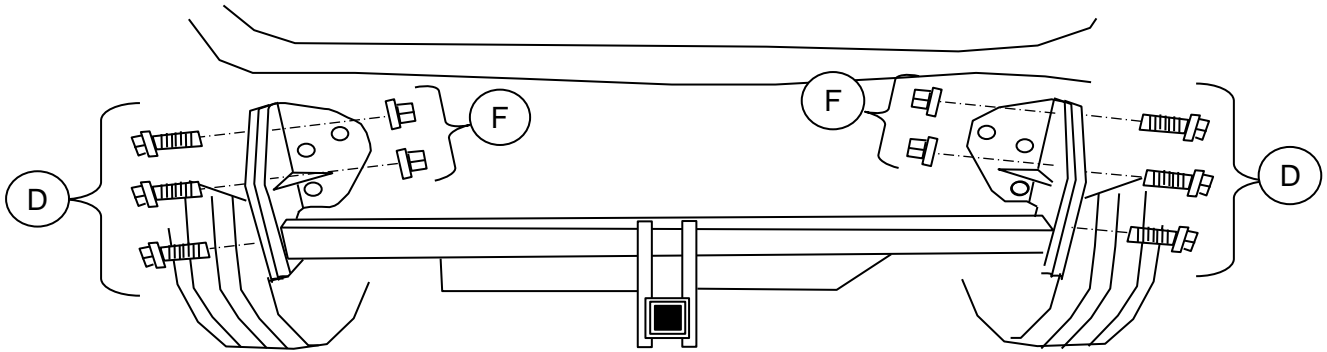

- ② Reinstall (1) of the bolts removed in Step 3-2 back into the frame on each side. Tighten each bolt to 60 Nm (44 ft-lbs)

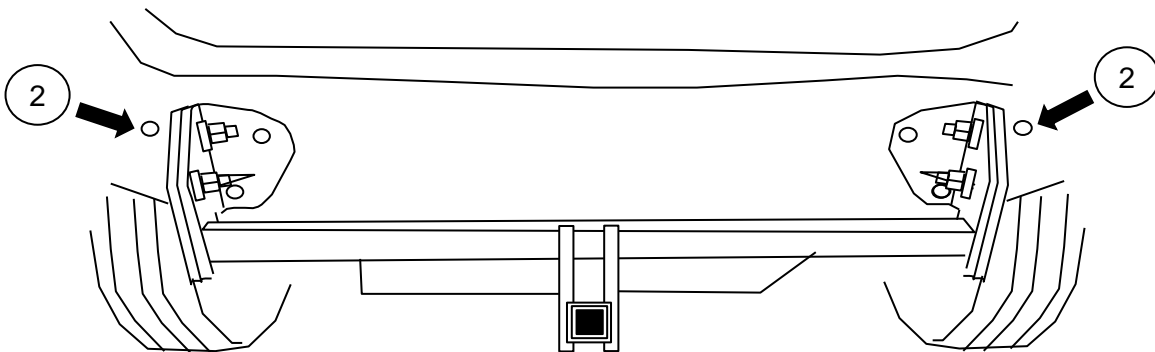

8 TORQUE FASTENERS



1 Torque all fasteners in the order and to the torque value as shown in the table

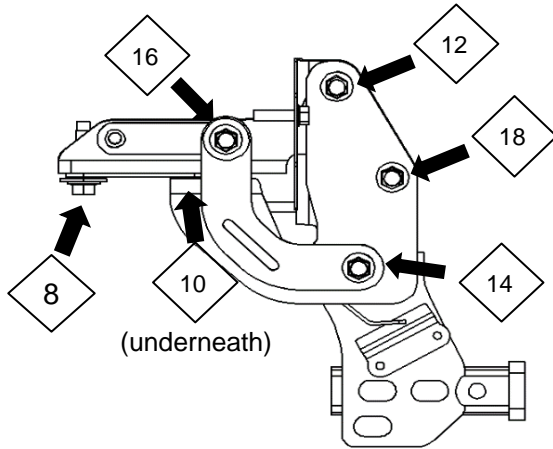

LH SIDE

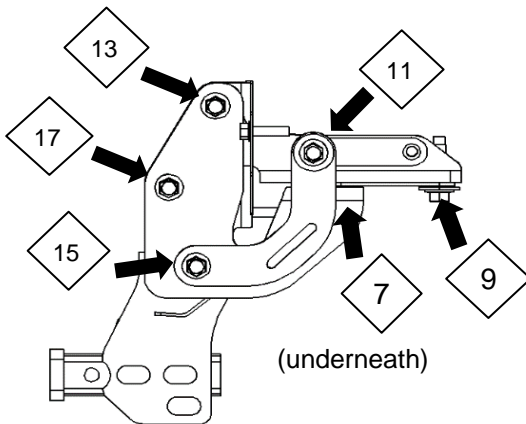

RH SIDE

ORDER	TORQUE (Nm)	TORQUE (ft-lb)	socket size (mm)
1	95±5	70±4	17
2	95±5	70±4	17
3	60±5	44±4	14
4	60±5	44±4	14
5	60±5	44±4	14
6	60±5	44±4	14
7	95±5	70±4	17
8	95±5	70±4	17
9	95±5	70±4	17
10	95±5	70±4	17
11	95±5	70±4	17
12	95±5	70±4	17 & 17mm wrench
13	95±5	70±4	17 & 17mm wrench
14	95±5	70±4	17
15	95±5	70±4	17
16	95±5	70±4	17
17	95±5	70±4	17 & 17mm wrench
18	95±5	70±4	17 & 17mm wrench

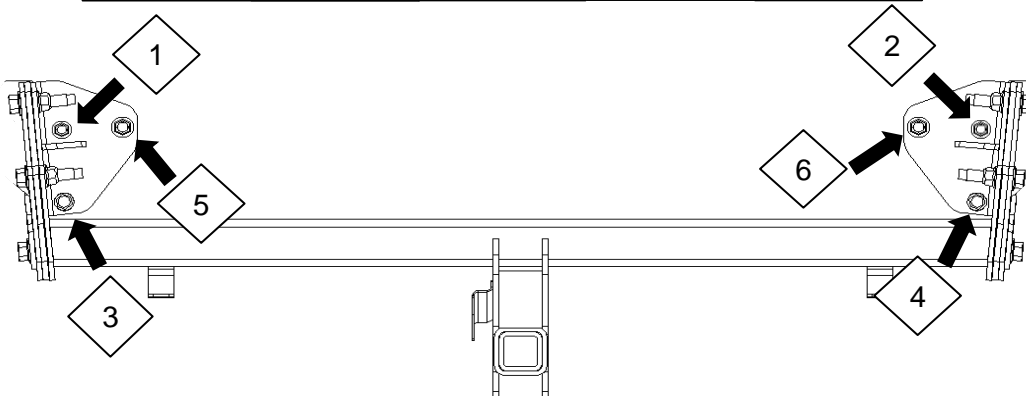
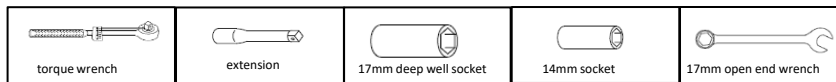

REAR

9 MODIFYING REAR BUMPER FASCIA

- 1 Move the fascia to a flat area in order to cut the "U" shape for the trailer hitch.
- 2 Remove the paper template on the next page and prepare as shown on that page.
- 3 Align the holes in the template to the holes on the inside of the bumper fascia.
- 4 With the template in place, mark the "U" shape.
- 5 Move the fascia to a flat area in order to cut the "U" shape for the trailer hitch.
- 6 Remove all burrs and rough edges after the cut is made.

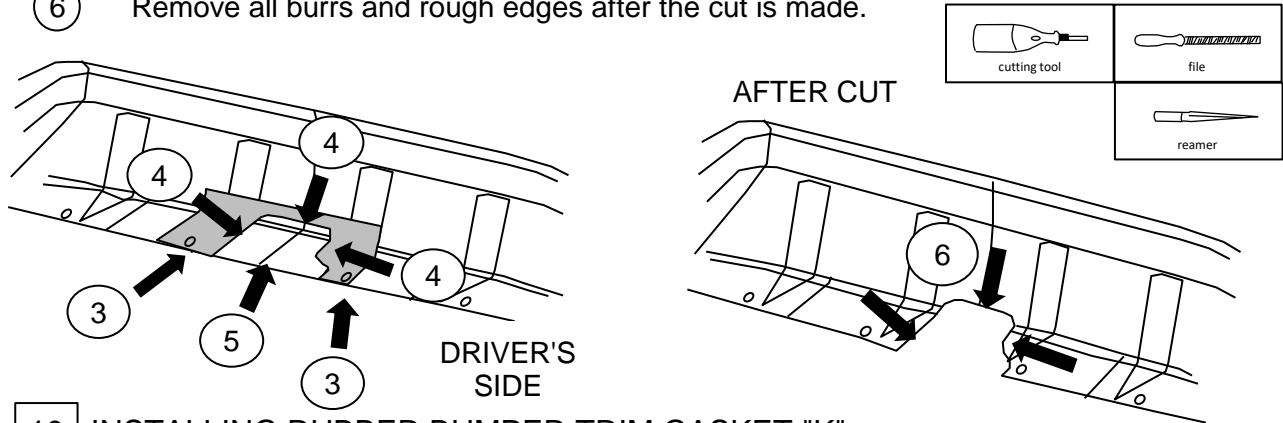

10 INSTALLING RUBBER BUMPER TRIM GASKET "K"

(follow steps 1-4 for Wilderness bumper, step 5 for Standard bumper)

- 1 Make sure the starting end of the gasket has a 90° square cut end.
- 2 Starting at one end of the bumper opening, carefully slide the gasket "J" along the edge. Continue to wrap around the opening, being sure to create a smooth joint as you go.
- 3 Wrap in a U-shape. Do not wrap around small bump out.
- 4 Once the gasket is in place, trim the excess length so that it is even with the edge.

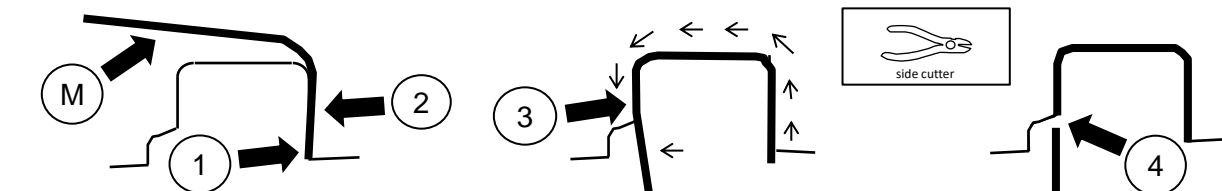

- 5 Slide the gasket "J" only along the straight, inboard edge. Trim the outboard edges at an angle as shown. Trim the pointed edge at the end to a square cut.

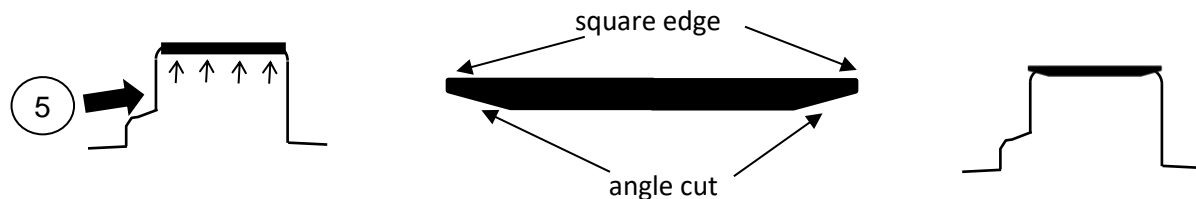

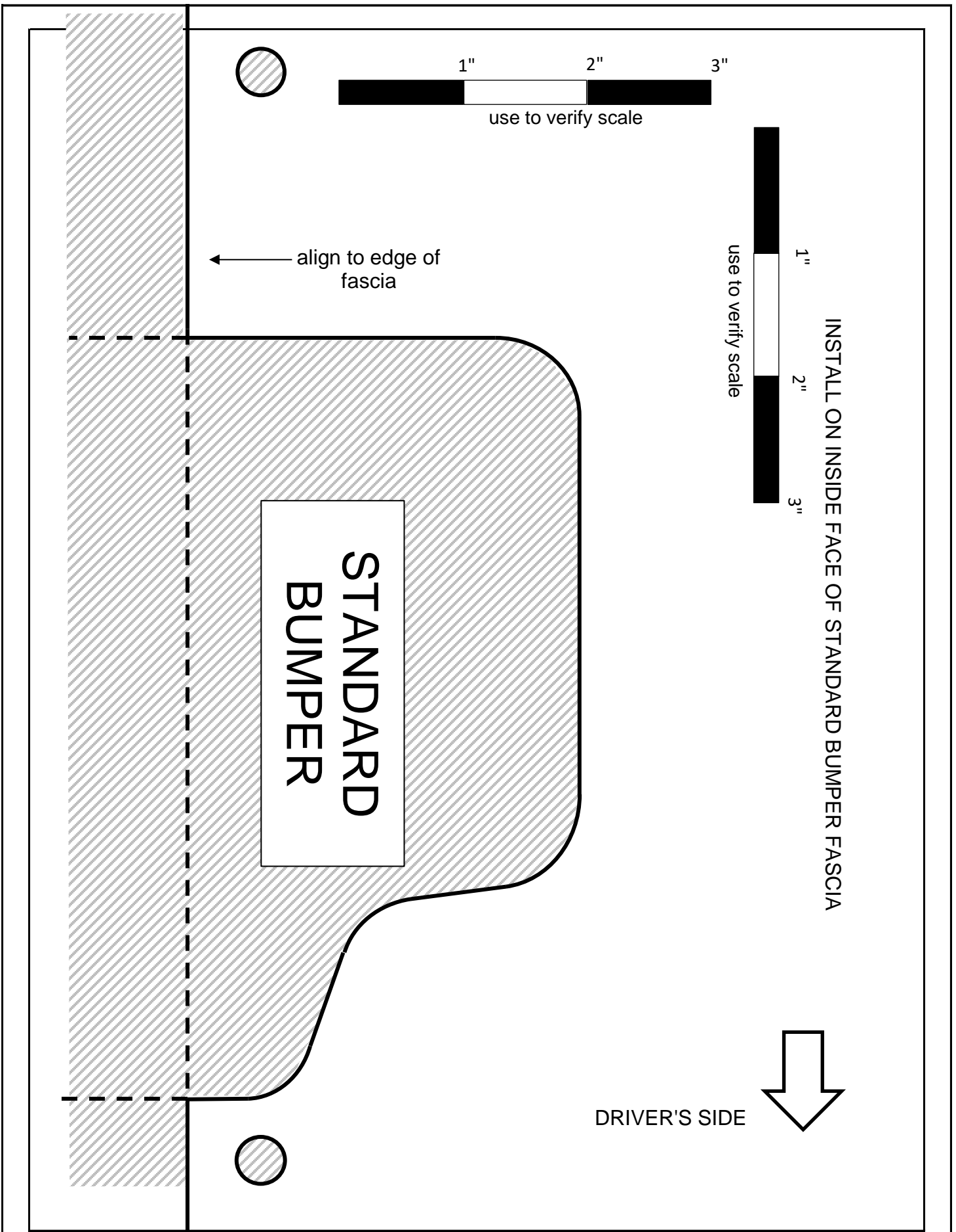

INSTALL ON INSIDE FACE OF WILDERNESS BUMPER FASCIA

WILDERNESS
BUMPER

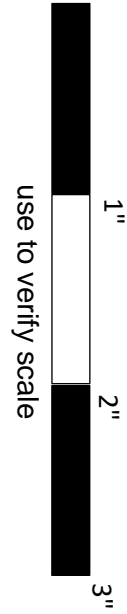
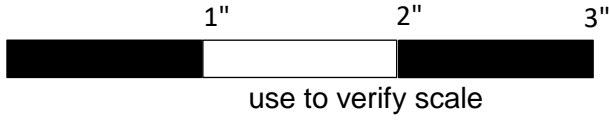

align to edge of fascia

cut out hole and align template lines to marks on inside of bumper

DRIVER'S SIDE

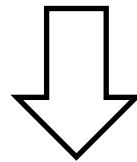

11 WIRING HARNESS INSTALLATION

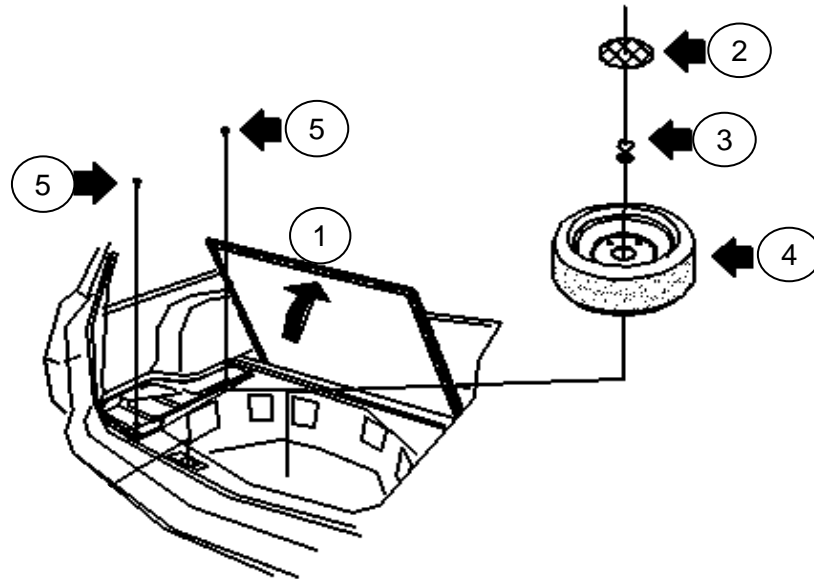

- ① Raise and remove the carpeted spare tire compartment cover.
- ② Remove tool tray
- ③ Unscrew and remove tire thumbscrew.
- ④ Remove spare tire.
- ⑤ Remove (4) push pin fasteners from side foam trays.
- ⑥ Remove (2) push pin fasteners to remove the rear inside trunk panel.
- ⑦ Remove rear tailgate trim.
- ⑧ Remove rubber plug from rear skirt panel.

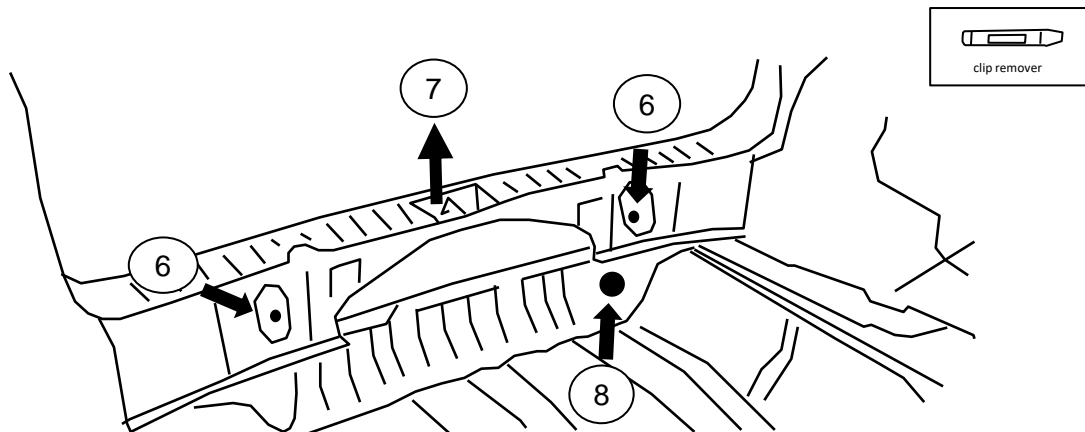

11 WIRING HARNESS INSTALLATION (CONT'D)

- 9 Locate the wiring harness pre-arranged connector at the LH side of the trunk.
- 10 Connect the tow hitch wiring harness to the vehicle side connector.
- 11 Route the wiring inside the rear trunk well as shown below.
- 12 Peel the backing off the double sided tape of the ECU and attach in the side of the spare tire area (a) as shown.
- 13 Peel the backing off the double sided tape on the fuse holder and attach to the rear of the spare tire well. Be sure they it not interfere with the spare tire.

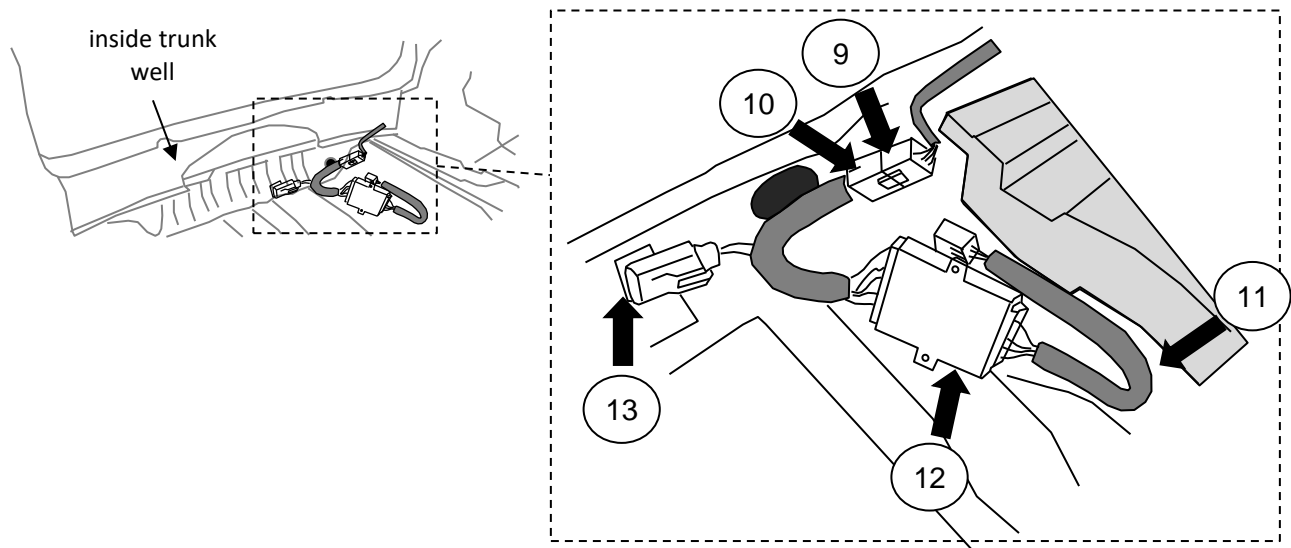

- 14 Install the 4-pin connector into the wiring harness mounting bracket on the tow hitch using the clamp bracket and hardware included in the wiring harness kit "I". Tighten the bolts to 5 ± 1 in-lb.

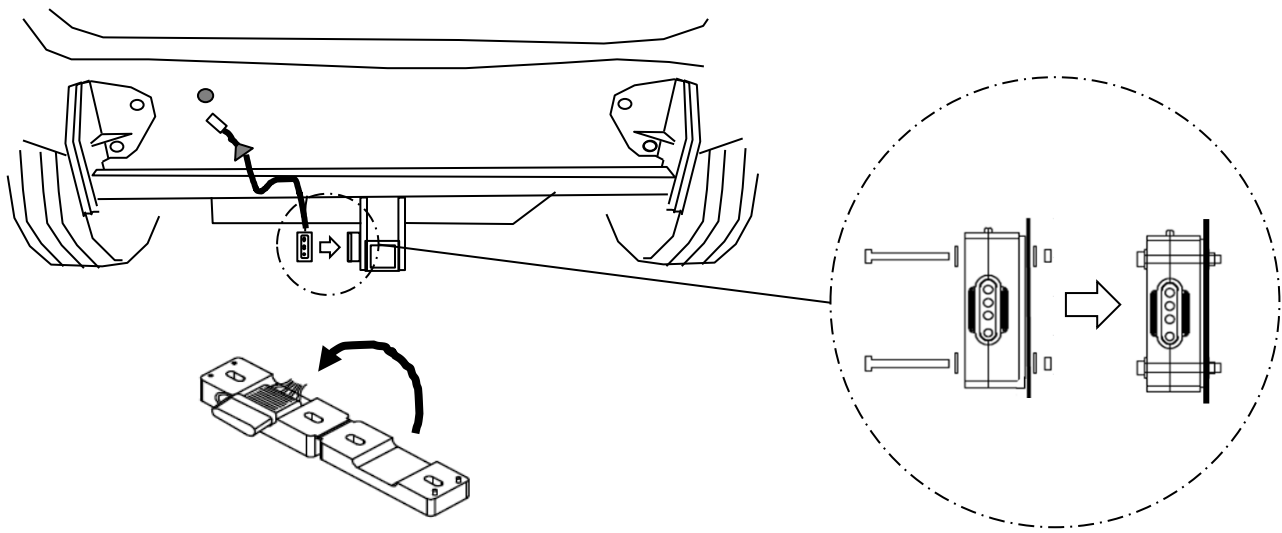

11 WIRING HARNESS INSTALLATION (CONT'D)

- 15 Route the connector at the opposite end through the hole in the rear panel and into the trunk area.
- 16 Install the rubber grommet into the hole.

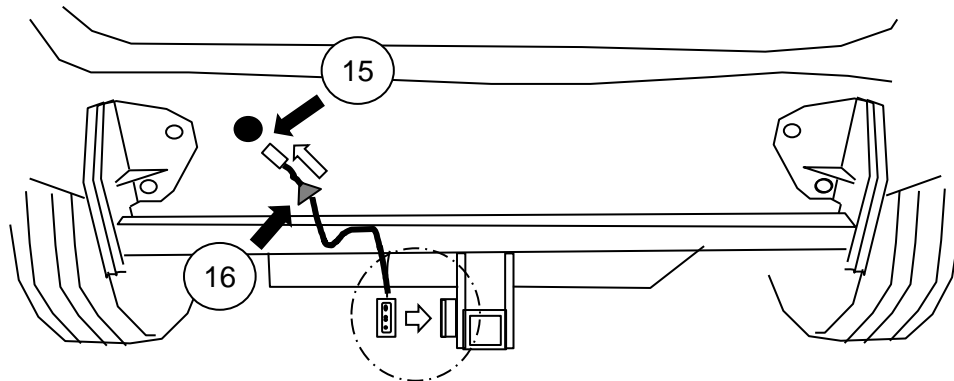

- 17 Secure the wiring harness to the hitch member tube with (2) long cable ties "K" as shown.

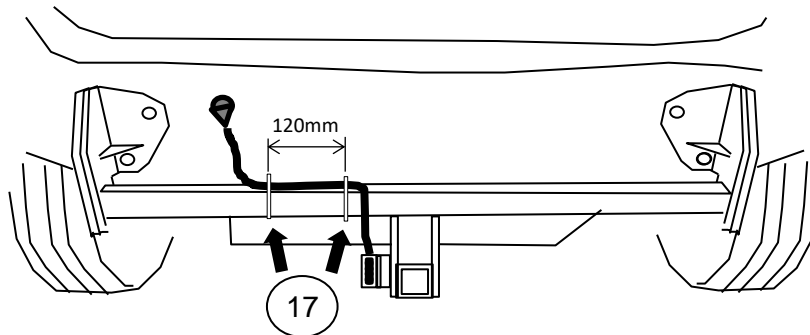

- 18 Attach the [RAB] connector to the L-shaped bracket on the LH side of the tow hitch by snapping the connector clip into the bracket slot.

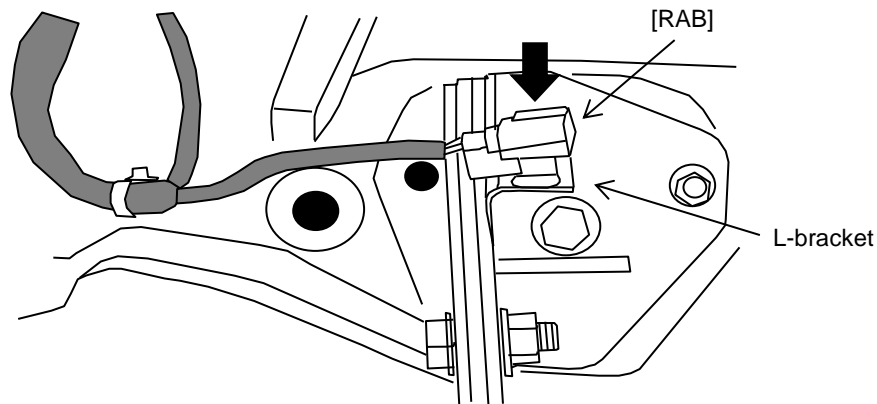

11 WIRING HARNESS INSTALLATION (CONT'D)

- 19 Inside the spare tire area, connect the 2 ends (inside and outside) of the wiring harness connector as shown below (a). Wrap both connector pairs with foam tape "L" (b). Use a cable tie "N" to secure the connection to the ECU through the hole in the ECU tab (c). Route the corrugated tubing as shown (d) and secure to the spare tire well using an adhesive-backed cable tie mount "M" and cable tie "N" (e)

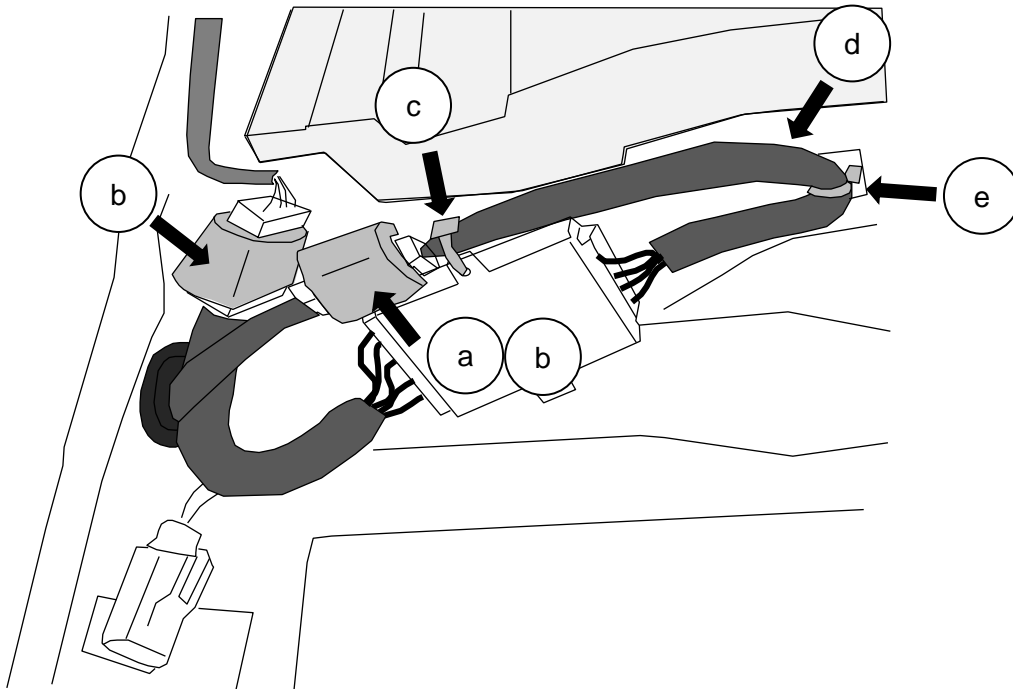

12 SAFETY CHAIN HOOK

- 1 Always use safety chains when towing.

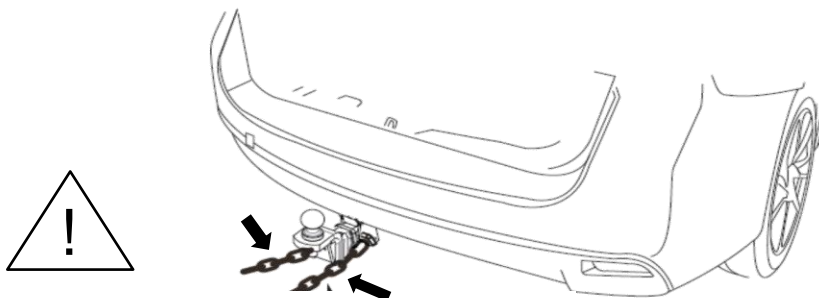

13 INSTALLATION INSTRUCTIONS

- 1 These instructions are an official document and an integral part of the trailer hitch. It should be stored in a glove box all the time and handed over with the vehicle if sold.

14 REINSTALLATION OF COMPONENTS

- 1 Reinstall outside lower covers.
- 2 Reconnect RAB harness
- 3 Reinstall rear bumper fascia.
Note: attach fascia to hitch member brackets using 2 push-pins
- 4 Reinstall rear tail lamps. Remember to reconnect wiring harness.
- 5 Reinstall rear tail light covers.
- 6 Reinstall spare tire and related components.
- 7 Replace rear compartment cover.

15 CAUTION



- 1 For further information, read vehicle's owners manual or consult your dealer or dealer's service department.
- 2 SUBARU accepts no liability for product defects caused by the vehicle owner or other persons and/or incorrect use.
- 3 After the first 600 miles, please consult with SUBARU dealer to re-check the tightness of Trailer Hitch bolts and/or nuts.
- 4 For models equipped with BSD (Blind Spot Detection) and RCTA (Rear Cross Traffic Alert) driving support systems, when towing a trailer, press BSD/RCTA OFF switch to deactivate the systems. The system may not operate properly due to the blocked radar waves. For details about BSD/RCTA OFF switch, refer to the owners manual "BSD/RCTA OFF switch".
- 5 For models equipped with RAB (Reverse Automatic Braking) system, please consult with SUBARU dealer when towing a trailer.