



FRONT LICENSE PLATE BRACKET - MOUNTING INSTRUCTIONS

CONTENTS:

- A. (1) MOUNTING BRACKET
- B. (2) ADHESIVE SPACER
- C. (2) WELL NUT #10-32
- D. (2) SCREW #10-32 X 1.25" 
- E. (2) SCREW #10 X 1" 
- F. (4) SCREW #10 X 0.5" (MOUNTING FRONT LICENSE PLATE) 

TOOLS REQUIRED:

- PHILLIPS-HEAD SCREW DRIVER
- 1/8" DRILL BIT
- 3/8" DRILL BIT
- DRILL

THERE ARE 2 POSSIBLE MOUNTING LOCATIONS ON THIS BRACKET. ALIGN THE BRACKET TO THE MOUNTING LOCATIONS ON THE FRONT OF YOUR VEHICLE. FOLLOW STEPS ACCORDINGLY

DISCLAIMER - BE SURE, WHEN INSTALLING THIS BRACKET, NOT TO BLOCK ANY ACCIDENT AVOIDANCE/PARKING SENSORS, HEADLAMPS OR VENTS TO ENGINE COMPARTMENT.



REV 4-15

PRE-EXISTING MOUNTING HOLES, FOLLOW STEPS BELOW.

STEP A: APPLY "ADHESIVE SPACER" TO THE "MOUNTING BRACKET"

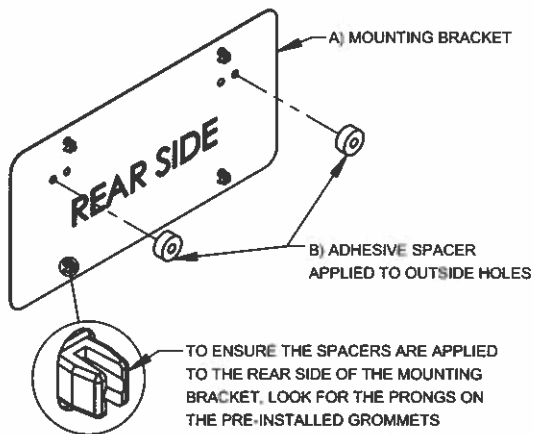

STEP B: ATTACH "MOUNTING BRACKET" TO VEHICLE

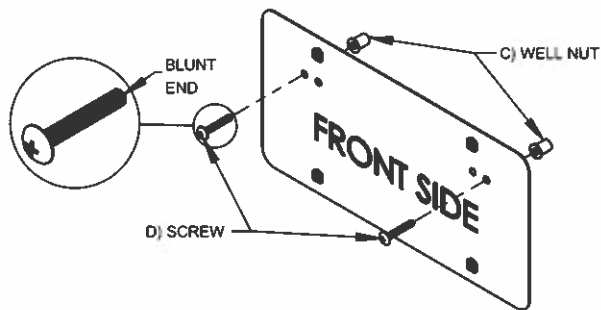

- INSERT WELL NUTS INTO THE EXISTING LICENSE PLATE MOUNTING HOLES, ON THE FRONT OF THE VEHICLE (WELL NUTS CAN BE PUSHED IN WITH A SCREWDRIVER IF THE FITMENT IS TOO TIGHT TO INSERT BY HAND).
- LINE UP MOUNTING BRACKET AND ATTACH TO THE VEHICLE USING (D) SCREW #10-32 X 1.25"
- TURN CLOCKWISE UNTIL BRACKET FEELS FIRMLY SEATED AGAINST THE BUMPER. DO NOT OVERTIGHTEN
- ATTACH LICENSE PLATE TO THE BRACKET USING (F) SCREW #10 X 0.5"

PRE-EXISTING MOUNTING DIMPLES, FOLLOW STEPS BELOW.

STEP A: APPLY "ADHESIVE SPACER" TO THE "MOUNTING BRACKET"

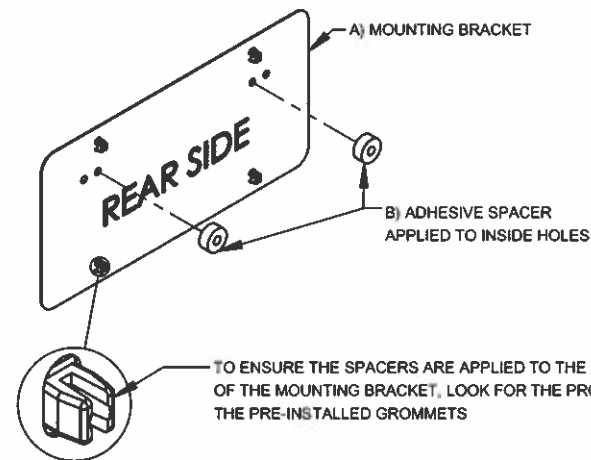

STEP B: ATTACH "MOUNTING BRACKET" TO VEHICLE

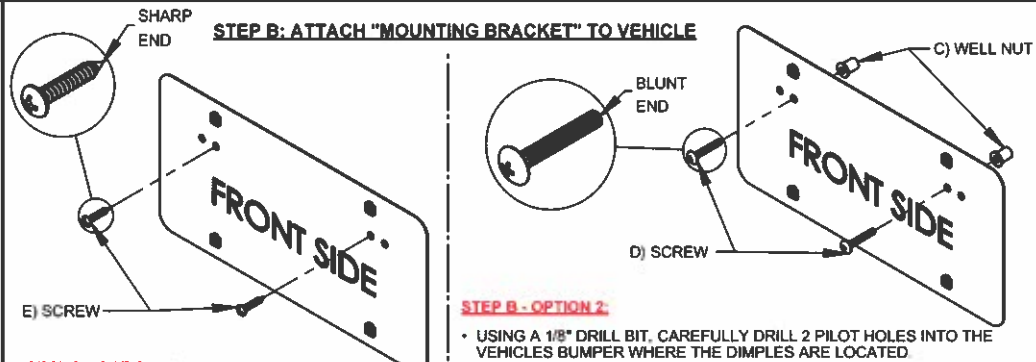

STEP B - OPTION 1:

- LINE UP MOUNTING BRACKET TO THE DIMPLES ON THE BUMPER AND ATTACH TO THE VEHICLE USING (E) SCREW #10 X 1"
- TURN CLOCKWISE UNTIL BRACKET FEELS FIRMLY SEATED AGAINST THE BUMPER. DO NOT OVERTIGHTEN
- ATTACH LICENSE PLATE TO THE BRACKET USING (F) SCREW #10 X 0.5"

STEP B - OPTION 2:

- USING A 1/8" DRILL BIT, CAREFULLY DRILL 2 PILOT HOLES INTO THE VEHICLES BUMPER WHERE THE DIMPLES ARE LOCATED
- USING A 3/8" DRILL BIT, CAREFULLY DRILL 7/8" INTO THE PILOT HOLES (A PIECE OF TAPE ON THE DRILL BIT CAN BE USED TO INDICATE DEPTH).
- INSERT WELL NUTS INTO THE NEWLY CREATED HOLES ON THE BUMPER.
- LINE UP MOUNTING BRACKET AND ATTACH TO THE VEHICLE USING (D) SCREW #10-32 X 1.25"
- TURN CLOCKWISE UNTIL BRACKET FEELS FIRMLY SEATED AGAINST THE BUMPER. DO NOT OVERTIGHTEN
- ATTACH LICENSE PLATE TO THE BRACKET USING (F) SCREW #10 X 0.5"