

**INSTALLATION INSTRUCTIONS**
**DESCRIPTION: Outback – Adjustable Crossbar Kit**

<b>A</b>	<b>Front Crossbar Assembly</b> (Clear Bag)	<b>B</b>	<b>Rear Crossbar Assembly</b> (Blue Bag)
<b>1X</b>		<b>1X</b>	

<b>C</b>	<b>T30 Torque Wrench</b>	<p>The Front Crossbar (A) has been designed to only fit in the Front Crossbar area and the Rear Crossbar (B) has been designed to only fit in Rear Crossbar Area.</p>	
<b>1X</b>			

**NOTE: MAXIMUM LOAD (170 lbs.) requirements can be found on the bottom face of the front crossbar. To minimize wind noise when the sunroof is tilted open, we recommend that the front crossbar be installed as far rearward on the side rails as possible when not using the crossbars to transport objects. Follow instructions that came with Genuine Subaru attachment accessories for proper placement of the crossbars when transporting objects.**

**MEANING OF CHARACTERS:**

**: CAUTION** – A process that must be carefully observed in order to reduce the risk of damage to the accessory/vehicle and to ensure a quality installation.



**: STOP** – Damage to the vehicle may occur. Do not proceed until process has been complied with.



**: TOOLS & EQUIPMENT** – Specific tools and equipment recommended for this process.



**INSTALLATION INSTRUCTIONS**

**DESCRIPTION: Outback – Adjustable Crossbar Kit**

**1** Remove the Front Crossbar (A) in the clear bag and the T30 Hex Key (C) from the packaging.

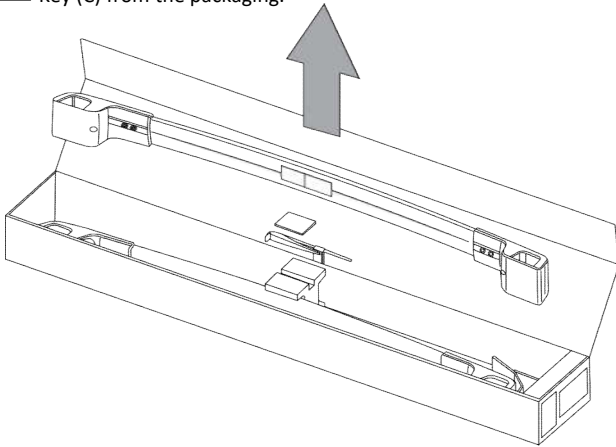

**2** Loosen the two top bolts on the Front Crossbar (A) until the bottom stanchions are able to drop and rotate.

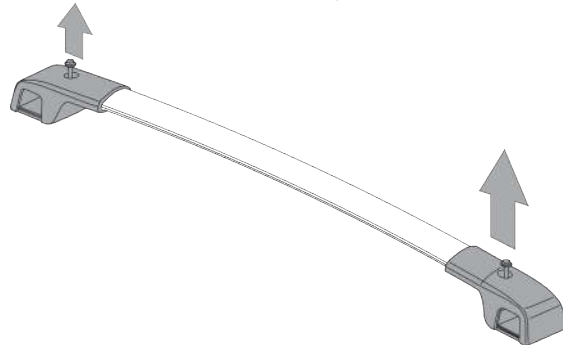

Note: The bolts do not need to be fully removed. They are long enough to be able to spin the bottom stanchions while still on the roof rails.

**3** Push the bottom stanchions downward and outward from the top stanchions and then swing each bottom 180°.

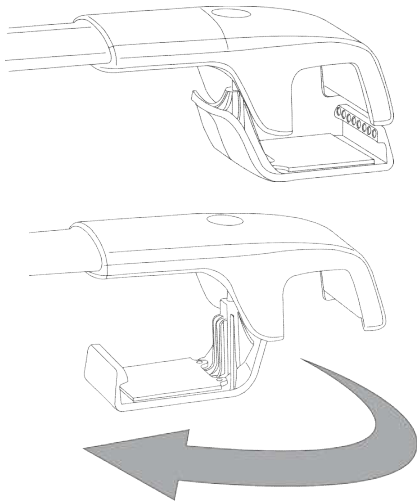

**4** Place the Front Crossbar (A) onto the roof rails. Orient using the front arrow molded on the underside of the crossbar.

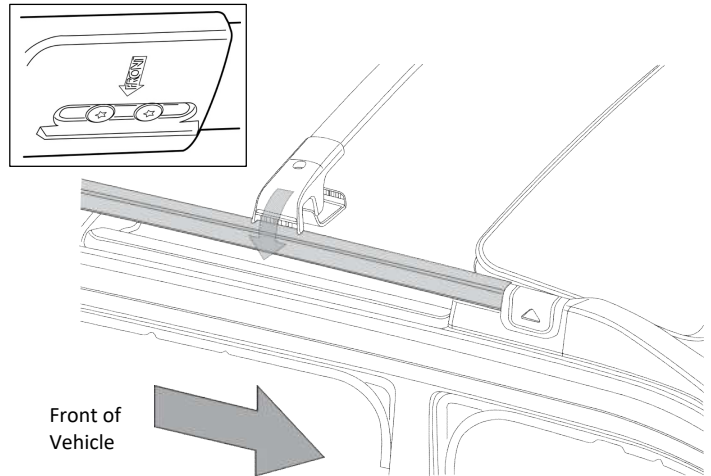

**5** Swing the Stanchions 180°.

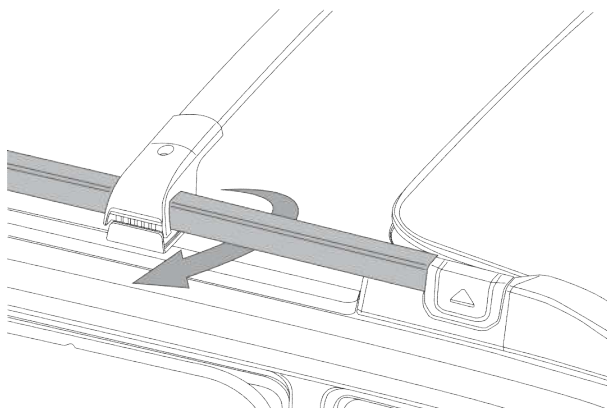

**6** Engage both parts together. Push the bottom piece towards the top piece until the front is nearly flush. Verify that the bottom piece is fully installed by checking the gaps and steps.

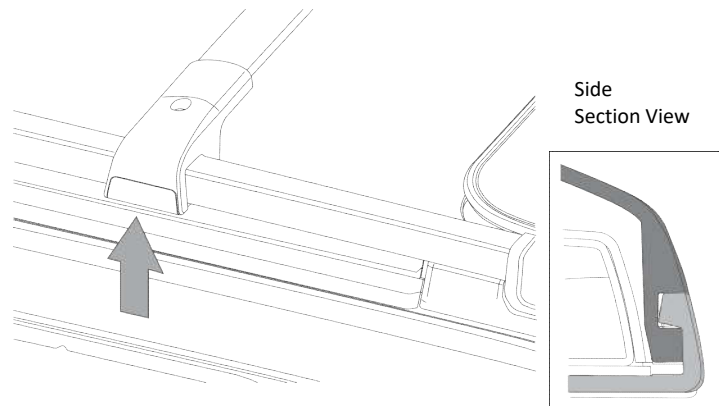



**INSTALLATION INSTRUCTIONS**

7

Tighten the bolts on the top of the Front Crossbar (A) using the supplied T30 Hex Key (C) to 8Nm. The bolt will be torqued to 8Nm when the end of the indicator goes to the line on the flag.

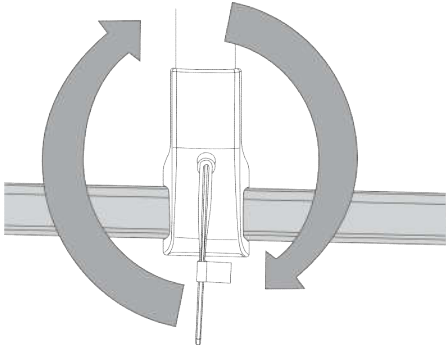

Torque: 8Nm ± 0.5Nm  
70.8 in-lbf ± 5.0 in-lbf

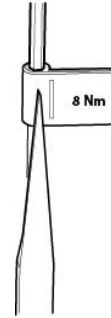

8

Repeat steps 1-7 for the Rear Crossbar (B) in the blue bag.

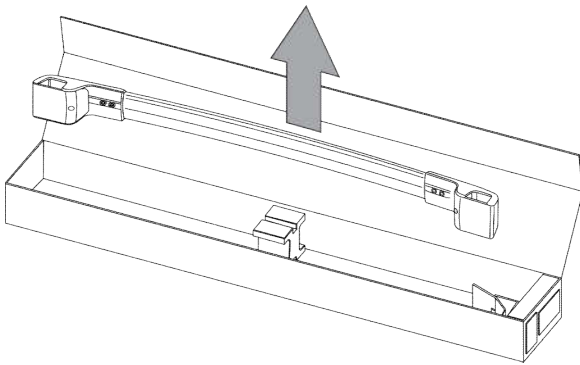

9

Verify both of the crossbars have a firm grip with the roof rail by trying to move each crossbar where each part is attached to the roof rails.

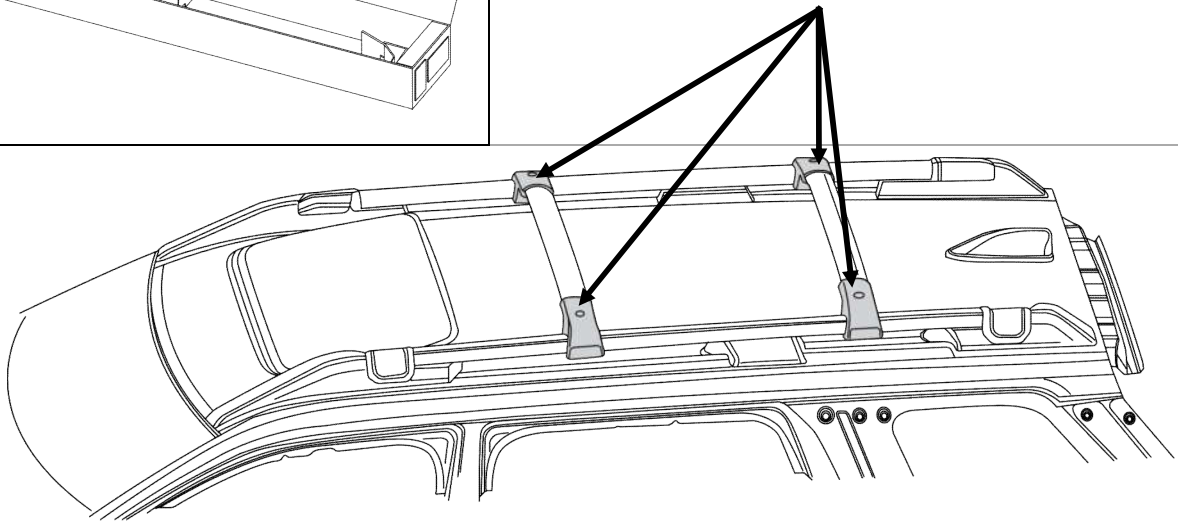

NOTE: Once crossbar installation is complete, store the T30 torque wrench in glovebox for future use.